

VF-A7

New-Generation High-performance Inverter TOSVERT™

To users of our inverters: Our inverters are designed to control the speeds of three-phase induction motors for general industry.

⚠ Precautions

- * Read the instruction manual before installing or operating the inverter unit and store it in a safe place for reference.
- * When using our inverters for equipment such as nuclear power control equipment, aviation and space flight control equipment, traffic equipment, and safety equipment, and there is a risk that any failure or malfunction of the inverter could directly endanger human life or cause injury, please contact our headquarters, branch, or office printed on the front and back covers of this catalogue. Such applications must be studied carefully.
- * When using our inverters for critical equipment, even though the inverters are manufactured under strict quality control always fit your equipment with safety devices to prevent serious accident or loss should the inverter fail (such as failure to issue an inverter trouble signal).
- * Do not use our inverters for any load other than three-phase induction motors.
- * None of Toshiba, its subsidiaries, affiliates or agents, shall be liable for any physical damages, including, without limitation, malfunction, anomaly, breakdown or any other problem that may occur to any apparatus in which the Toshiba inverter is incorporated or to any equipment that is used in combination with the Toshiba inverter. Nor shall Toshiba, its subsidiaries, affiliates or agents be liable for any compensatory damages resulting from such utilization, including compensation for special, indirect, incidental, consequential, punitive or exemplary damages, or for loss of profit, income or data, even if the user has been advised or apprised of the likelihood of the occurrence of such loss or damages.

For further information, please contact your nearest Toshiba Representative or International Operations-Producer Goods.
The information in this brochure is subject to change without notice.

In Touch with Tomorrow
TOSHIBA

TOSHIBA CORPORATION
SOCIAL INFRASTRUCTURE SYSTEMS COMPANY

Industrial Equipment Department
1-1, Shibaura 1-chome, Minato-ku,
Tokyo 105-8001, Japan
Tel.: (03)3457-4880 Fax.: (03)5444-9268



Noise filter inside: 200V 0.4 to 7.5kW/400V 0.75 to 15kW

Advanced sensorless vector control

Flexibility and application extensibility

Automatic setting functions

200V class 0.4 to 90kW

400V class 0.75 to 280kW



Noise filter inside

200V class 0.4 to 7.5kW models
400V class 0.75 to 15kW models



Complies with the CE marking requirements

The 200V class 0.4 to 7.5kW and 400V class 0.75 to 15kW models comply with the CE marking requirements, since they install EMI noise filters inside conforming to the EMC directive. The other models also can satisfy the EMC directive and the low-voltage directive if they are used together with a noise filter recommended by Toshiba. For details, please refer to the instruction manual.



UL



Soon to be released

ISO 9001

VF-A7 series is manufactured at the works, which has received the international quality assurance standard ISO 9001 certification.
Registration No.: 200594
Registration date: February 15, 2002

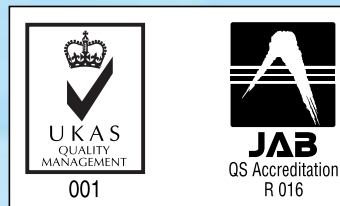

ISO 14001

The works producing the VF-A7 series is registered as an environment management system factory specified by ISO 14001.

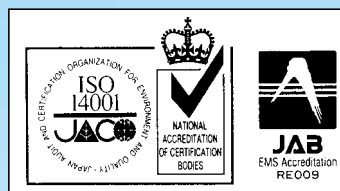

Renewal : 200V 37 to 90kW 400V 37 to 280kW

- ① Compact!
- ② Fin can be attached externally!

Line-up

200V class	applicable motor power	400V class
VFA7-2004PL	0.4kW	
VFA7-2007PL	0.75kW	VFA7-4007PL
VFA7-2015PL	1.5kW	VFA7-4015PL
VFA7-2022PL	2.2kW	VFA7-4022PL
VFA7-2037PL	3.7kW	VFA7-4037PL
VFA7-2055PL	5.5kW	VFA7-4055PL
VFA7-2075PL	7.5kW	VFA7-4075PL
VFA7-2110P	11kW	VFA7-4110PL
VFA7-2150P	15kW	VFA7-4150PL
VFA7-2185P	18.5kW	VFA7-4185P
VFA7-2220P	22kW	VFA7-4220P
VFA7-2300P	30kW	VFA7-4300P
VFA7-2370P1	37kW	VFA7-4370P1
VFA7-2450P1	45kW	VFA7-4450P1
VFA7-2550P1	55kW	VFA7-4550P1
VFA7-2750P1	75kW	VFA7-4750P1
VFA7-2900P1	90kW	VFA7-4110KP1
	110kW	
	132kW	VFA7-4132KP1
	160kW	VFA7-4160KP1
	220kW	VFA7-4220KP1
	280kW	VFA7-4280KP1

Contents

Flexibility for a wide variety of Drive systems.....	5	Terminal functions.....	16
Three in One.....	6	Basic and extended parameters.....	17
VF-A7 optimally controls any type of machine.....	7	Protections.....	21
Various functions for a wide range of applications...	9	Application knowledge.....	23
Standard specification.....	10	Application and functions of options.....	27
External dimensions.....	13	Add-on module/board type options.....	28
Standard connection.....	15	Stand-alone options.....	29



Noise filter inside
 200V class 0.4 to 7.5kW models
 400V class 0.75 to 15kW models

Superb Feature 1

VF-A7 solves problems caused by EMI noise.

Noise reduction

Both 200V class 0.4 to 7.5kW models and 400V class 0.4 to 15kW models install EMI noise filter inside, which significantly reduce conducted and radiated noise, and thus to satisfy the CE marking requirements in EU.

Saving-space and easy wiring

The VF-A7 with EMI noise filter inside can be installed in a space 14 to 30% smaller than that required for an inverter with an external noise filter. In addition, it relieves you of wiring between it and a stand-alone noise filter.

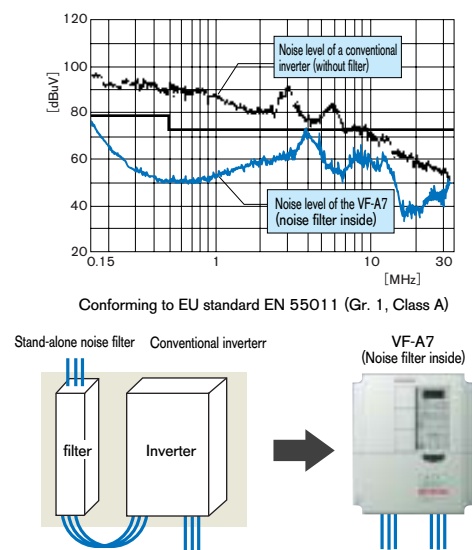

Superb Feature 3

VF-A7 has a wide variety of options useful for a wide range of applications.

- Extended panel/Parameter writer
- Communication (Standard) (RS485)
- Communication (Optional) (RS232C, RS485, TOSLINE-F10M, TOSLINE-S20, LonWorks^(*), DeviceNet^(*), ProfiBus^(*))
- Add-on module options for vector control with sensor^(*) (Speed feedback, positioning control, torque control)
- Extended terminal board add-on cassette options^(*)
 - (1) 12/16-bit binary, 3/4-digit BCD input
 - (2) Extended input terminal (8 contacts)
 - (3) Programmable analog output terminal (current/voltage output)
 - (4) Programmable relay output terminal (2 circuits)
- Control power supply unit (up to 22kW models)
- Board type options for vector control with sensor
- Flange mounting kit^(*)



Superb Feature 2

VF-A7 enhances the dynamic performance of motors.

More than 200% torque even at 0.5Hz

The VF-A7 significantly increases the starting torque of the motor; VF-A7 produce more than 200% torque even at extremely low speeds. With the speed control range widened to 1:150, the VF-A7 can be used for higher-performance machines.

On-line automatic-tuning function

The VF-A7 has an online automatic-tuning function to automatically correct the motor constants for sensorless vector control even during operation. With this function, the VF-A7 enables the motor to accurately run and stably produce large torque without being affected by motor temperature.

Torque control^(*)

In addition to speed control by frequency reference signals, the VF-A7 can control motor torque by torque reference signals. Suitable for use in winding application, etc.

Torque limit

To prevent the machine from being damaged by excessive torque or the VF-A7 itself from tripping, the VF-A7 has the function of limiting the output torque of the motor.

Tap-stop control

When used for a conveyor application, the VF-A7 limits the torque produced by the motor so that the system can make a stable tap-stop.

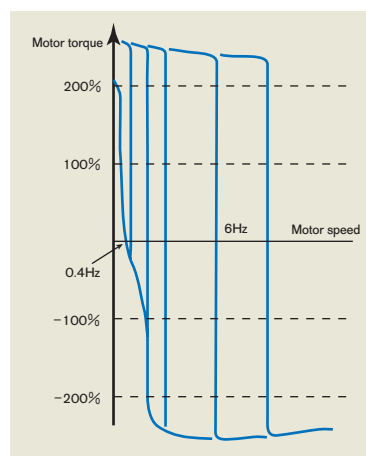

Example torque characteristics of VFA7-2037PL with a 4P-3.7kw standard motor.

Superb Feature 4

VF-A7 can be applied to a wide range of applications from simple speed control to system application.

Automatic setting function

All you have to do for simple speed control for start-up is to connect it to a motor and a power supply source; the VF-A7 does not require cumbersome parameter setting to start operation.

- (1) Automatic adjustment of acceleration/deceleration times
 The VF-A7 automatically adjusts the acceleration/deceleration times according to the load applied. (The acceleration and deceleration times are changed constantly.)
- (2) Automatic V/f mode setting
 Sensorless vector control and on-line automatic tuning are settled at a time. So if you want to increase the starting torque and suppress the speed variance, easily can be settled and performed.

Flexibility and extensibility for system application

- The function of high speed operating at low load which improves the efficiency of operation, especially when the VF-A7 is used for crane/hoist application
- Vector control with sensor, which enable to control the torque, speed, position, of a motor with a higher accuracy
- Drooping control function ensuring optimum load sharing
- Override function useful for fine adjustment of line speed
- Sink/source and input/output logic switchable, which are convenient when the VF-A7 is used in combination with a programmable controller.
- Commercial power/inverter switching function which sufficiently backs up commercial power
- Input phase failure protective function which protects the capacitors in the main circuit
- Various communication functions can enable VF-A7 to be applied to system applications.

*1. At a sensorless vector control mode, torque control cannot be used for low-load, low speed area. Use torque control with sensor when more accurate control is required.
 *2. Soon to be released
 *3. Use attachment for mounting add-on module options.

Flexibility for a wide variety of Drive systems

Easy communication with inverters

The communication options makes it more easy for setting and operating the VF-A7 inverter.

1 Extended panel

This operating panel is designed to set and operate the VF-A7 inverter with it attached on an inverter panel or from a remote place.

2 Parameter writer

Designed for reading, copying and writing preset parameters by a single operation, so easily set the same parameters for two or more inverters of the same capacity. This unit can store parameters for up to three inverters at a time.

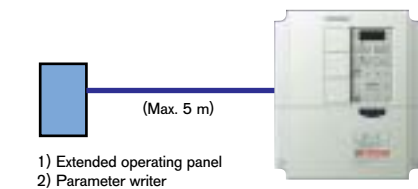

3 RS232C conversion unit

This unit allows you to easily set parameters, store or write data, communicating with a personal computer via an interface cable. This RS232C unit is a very useful communication tool which can be connected with two inverters simultaneously.

- Monitoring function
- Command function
- Parameter setting function
- Additional functions

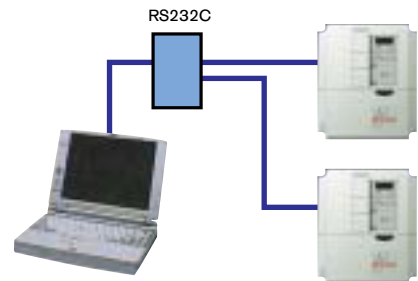

Centralized control of inverters by a communication system

A number of inverters can be controlled easily by means of a communication system. The means of communication can be selected from among a personal computer, a programmable controller and a higher order network.

1 RS485 conversion unit

- Computer link
With this unit, you can establish a network for data communication between a host computer and inverters.
- Communication between inverters up to 64 units.
Without or with this unit, you can establish a frequency data communication network to carry out proportional operation of two or more inverters.

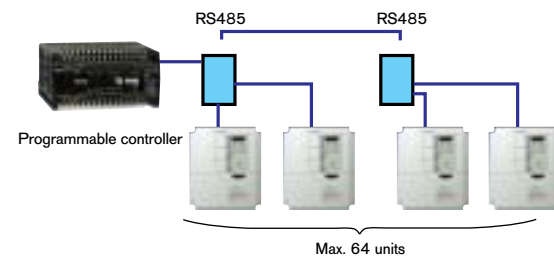

2 TOSHIBA Field network

- TOSLINE-F10M
- TOSLINE-S20

3 Open network

- Lon Works ^{(*)1}
- Device Net ^{(*)1}
- Profibus ^{(*)1}



*1. Soon to be released

Three in one - Inverter playing three different roles

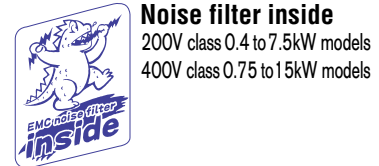

Sensorless vector control mode

If you use a standard motor (irrespective of its manufacturer) and Then,

- If you need larger starting torque and
- More smoothly and stably operation even at extremely low speeds,
- If you want to reduce load fluctuations due to slip of the motor, or
- If you want to keep large torque at extremely low speeds, you can use the sensorless vector control function, just by setting on-line automatic-tuning. (*)



As a matter of course, the control mode can also be selected from among the conventional constant V/f control mode, automatic torque boost mode, variable torque mode and energy-saving mode.

(*) On-line automatic tuning can be performed with the motor kept in operation.

Torque control mode with/ a sensor

Use this mode, for example, if you want to keep even the tension at a winding application, etc.

- Motor torque can be controlled by combining a motor with sensor and the VF-A7 with PG feed back option unit.
- Motor torque can be controlled by analog signals. (The rotating speed of a motor is determined by the relationship between the load torque and the motor output torque.)
- The torque reference can be selected from 0 to +/-10 (5) V or 4 to 20 mA and 12/16-bit binary(option) and BCD input(option).

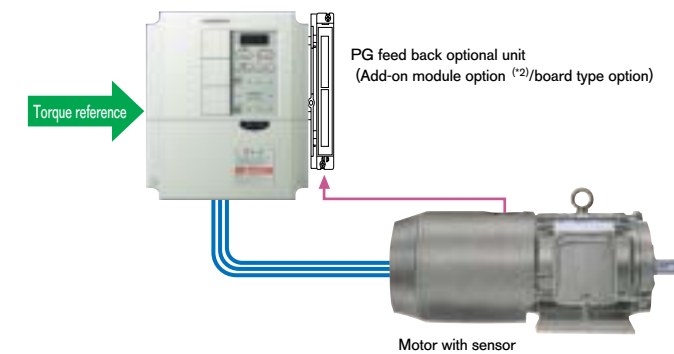

Note) The VF-A7 can control torque without using a sensor. Note, however, its control accuracy deteriorates under low-load, or low-speed conditions.

Speed/positioning control mode with a sensor

- Combining a motor with a sensor and the VF-A7 with PG feed back option unit makes it possible to control the speed and position with a higher accuracy.
- In the positioning mode, the displacement and speed are adjusted using pulse reference. In this mode, the machine returns to its original position even if it is displaced because of external force.
- For injection molding machines, etc., this Combination can be used as an unsophisticated servo.

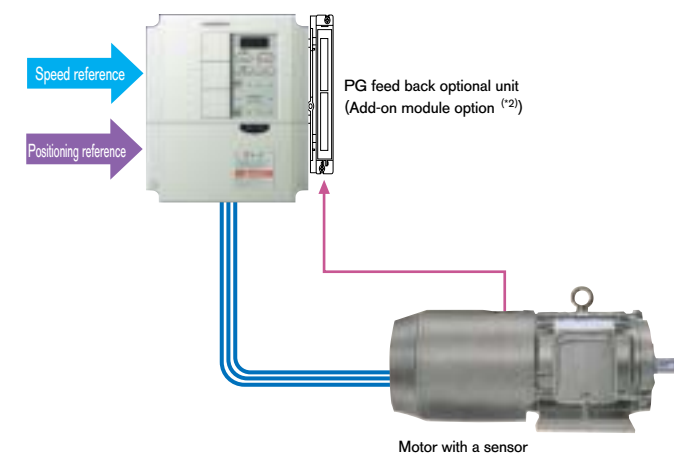

*2. Use attachment for mounting add-on module options.



Noise filter inside
200V class 0.4 to 7.5kW models
400V class 0.75 to 15kW models

VF-A7 optimally controls any type of machine.

(1) Industrial machinery in general

Distribution and conveyor systems ... crane, hoist, automated warehouse
Textile machines ... Chemical fiber dyeing, finishing and spinning machines
Machining and machine tools ... Laths

- (2) Fan, blower and pump: Fan, pump, air conditioning system
- (3) Automatic service apparatus: Fitness apparatus, medical apparatus, washing machine
- (4) High-tech systems and high-performance machines: Paper and film transfer/printing systems
- (5) Simple positioning application: Elevator, extruding machine, injection molding machine, printing machine

Crane/hoist

Preset-speed operation.... Preset-speed settings (Max. 16 preset speeds)
Combination with brake motors.... The VF-A7 makes the motor produce large torque even in extremely low speed ranges, thus can apply enough starting torque to the machine.
Speed change according to load.... The high-speed operation at low-load function makes it possible.
Driving up to 4 motors by one inverter.... Up to four motors can be driven simultaneously.
Keeping torque even when voltage.. The VF-A7 compensates for voltage drop to maintain the low-speed torque at a required level.
High accuracy required for operation.... Sensorless vector control and on-line auto-tuning ensure accurate and smooth operation even in low speed ranges. The vector control with sensor is more useful for machines which require a still higher control accuracy. (An add-on module or board option is required)

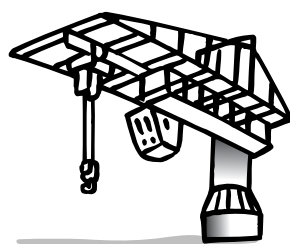

High-tech systems and high performance machines

Paper/film transfer and printing systems

Torque control..... The motor torque can be controlled freely by external signals. This function is suited for winding application which need to keep the tension of paper, film, etc., even.
Drooping control..... This function can perform optimum load sharing.
Communication function.... This function allows centralized control of two or more inverters.
Digital reference input.... 12/16-bit binary input or BCD input can be used as reference (extended terminal board add-on module option) .
PG feed back options... (Add-on module options/ board type options) These options are designed for improving the accuracy of speed control, torque control and positioning control.



Fans and blowers

Noise filter inside..... The noise filter inside prevents nearby peripheral electronic devices from malfunctioning, and also reduces noise affecting on a radio, etc. ^(*) So, suitable for air conditioning systems installed in buildings.
Commercial powerinverter..... operation switchable The power source can be switched just by using output signals, so there is no need to install a time relay, or the like.
Automatic energy-saving... operation The VF-A7 efficiently saves energy by properly controlling current applied to the motor.
Auto-restart after a momentary... power failure This function enables the motor to restart even under coasting conditions.
Monitoring function Standard monitor display can be selected from 29 items. Such as output current, input or output power.

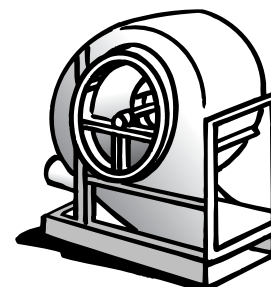

Pumps

Noise filter inside..... The built-in noise filter prevents nearby electric and electronic systems from malfunctioning, and reduces noise affecting on a radio, telephone, etc. ^(*)
Automatic energy-saving operation... The VF-A7 efficiently saves energy by properly controlling current applied to the motor.
PID control..... Flow rate, room temperature, water level, etc., can be kept constant, by taking in the feed back signal from sensor.
Commercial powerinverter..... operation switchable The power source can be switched just by using output signals. So there is no need to install a time relay, or the like.

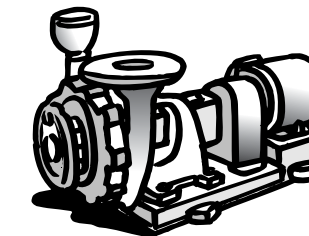

Transfer systems conveyor

Enough starting torque ... More than 200% starting torque at 0.5 Hz
Preset-speed operation ... Preset-speed settings (Max. 16 preset speed)
Driving up to 4 motors.... by one inverter Up to four motors can be driven simultaneously.
High accuracy required for operation... Vector control and on-line auto-tuning ensure accurate and smooth operation even in low speed ranges. The vector control with sensor is more useful for machines which require a still higher control accuracy. (An add-on module option, board option is required.)

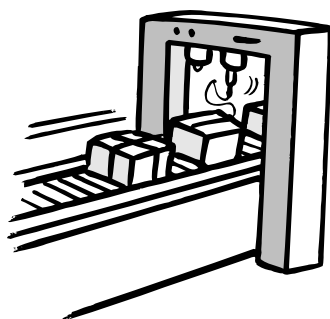

Automatic service apparatus

Fitness apparatus, medical apparatus, washing machine

Noise filter inside..... The noise filter inside prevents peripheral electronic devices from malfunctioning, and also reduces noise affecting on a radio, telephone, etc. ^(*)
Smooth operation at low speeds... Sensorless vector control and on-line auto-tuning ensure smooth operation even in low speed ranges.
More than 200% torque at 0.5 Hz... The VF-A7 produces large torque even at low speeds, so it is suitable for dyeing machines, fitness apparatus (Room Runner), etc. which require large torque in low speed ranges.
Operating direction switchable.. by analogue signals The operating direction can be switched between forward and reverse by applying a DC voltage of +/-10V.

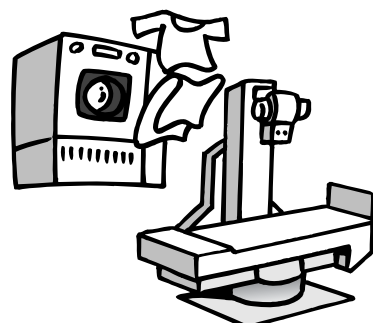

Machine tools

Prevention of breakage of drills... The overtorque detecting/limiting function is effective for preventing the breakage of drills.
Digital reference input.... 12/16-bit binary input or BCD input can be used as reference if an option (extended terminal add-on cassette option) is added.
High accuracy required for operation... Sensorless vector control and on-line auto-tuning ensure accurate and smooth operation even in low speed ranges. The vector control with sensor is more useful for machines which require a still higher control accuracy. (An add-on module, board type option is required.)
Operating direction switchable.. with an analog signals The operating direction can be switched between forward and reverse by applying a DC voltage of +/-10V.

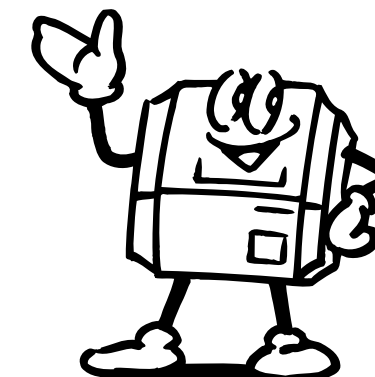
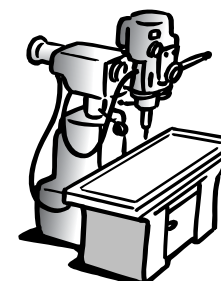

*1: 200V 0.4-7.5kW models 400V 0.75-15kW models

Various functions for a wide range of applications

Function for crane/hoist application

Function intended for lifting gears
Especially useful when the VF-A7 is used for crane/hoist application. This function is designed to:

- Detect the load applied to the motor and increase its rotating speed to improve the machine's running efficiency, if the load is found to be relatively small,
- Detect the output torque and release the brake when the torque rises high enough, and

Drooping function

Designed to prevent a load from being applied to a single inverter, when two or more inverters are used to drive a motor.

Special analog input

The following constants can be adjusted under control of analog signals

- Acceleration/deceleration time reference frequency
- Upper-limit frequency
- Acceleration/deceleration time
- Manual torque boost amount

Standard display mode selection function

Items displayed when the power is turned on can be selected. By default, frequency is displayed but it can be changed to output current, input/output power, and so on.

Input/output programmable terminal functions

- A new menu item is added to the menu of the programmable terminal functions.
- The VF-A7 supports the entry by means of a-contact, in addition to b-contact which is the only one contact available to conventional models.

1) a-contact

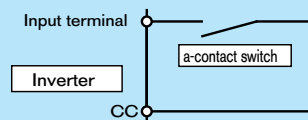

* Shorting the circuit formed by the input terminal and the CC (common) terminal causes active. Suitable for forward/reverse switching, preset-speed operation, etc

2) b-contact

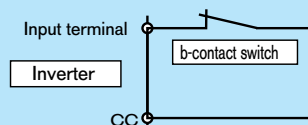

* Breaking the circuit formed by the input terminal and the CC (common) terminal causes active. Suitable for input of standby signals, reset signals, etc.

Sink/source switching function

For this switching, the plus common (P24) control terminal also can be used, in addition to the minus common (CC) terminal which is the only one terminal available to convenient models.

1 to 4 motors switching

The VF-A7 is capable of V/f switching of up to four motors, while the number of motors that conventional models can switch is two.

Commercial power/inverter switching function

The power source can be switched between the commercial power and the inverter, by switching the sequencer in it. (An external MCCB, etc., is required for this switching.)

PID control

The PID control function built in as standard performs PID control by signals feed back from a process converter such as pressure sensor.

Priority selection of input terminal

The control mode can be switched to frequency control with an input terminal, without using any switching sequence, while the operation frequency is being set from the control panel.

Input-phase failure protection

This function trips the inverter in case one of the three phase on the input side is failed.

Patterned operation function

This function is an unsophisticated PLC function which is designed to carry out operation in programmed patterns.

Override function

The preset frequency control values can be adjusted by impressing signals from an external control unit.

V/f 5-point settings

V/f characteristics can be set arbitrarily.

Preset-speed operation mode

When a machine is operated at preset speeds, different acceleration/deceleration time, torque limit and V/f characteristic can be selected on a speed-by-speed basis.

Standard specifications



Noise filter inside
200V class 0.4 to 7.5kW models
400V class 0.75 to 15kW models

Model and standard specifications (Small- and middle-capacity models)

200V series

Item		Standard specification														
Applicable motor (kW)		0.4	0.75	1.5	2.2	3.7	5.5	7.5	11	15	18.5	22	30	37	45	55
Rating	Type	VFA7-														
	Model	2004PL	2007PL	2015PL	2022PL	2037PL	2055PL	2075PL	2110P	2150P	2185P	2220P	2300P	2370P1	2450P1	2550P1
	Capacity (kVA) *1	1.0	2.0	3.0	4.0	6.5	9.5	13	19	25	28	34	46	55	69	84
	Rated output current (A)	3.0	5.0	8.0	10.5	16.6	25	33	49	66	73	88	120	144	180	220
	Rated output voltage	3phase 200 to 230V (The max. output voltage is the same as the input source voltage.)														
Electrical braking	Overload current rating	2 minutes at 150%, 0.5 seconds at 215%														
	Dynamic braking circuit	Dynamic braking circuit installed										Optional				
	Electrical braking	Dynamic braking resistor	Built-in braking resistor		Braking resistor or external braking unit (optional)											
			Rating: 120W-70Ω	Rating: 120W-40Ω												
Input Power	Voltage/frequency	Main circuit	3-phase 200 to 230V - 50/60Hz						3-phase 200 to 220V - 50Hz 200 to 230V - 60Hz							
		Control circuit *2	External circuit (optional)										Single-phase 200 to 220V - 50Hz 200 to 230V - 60Hz			
	Tolerance	Voltage +10/-15% *4, frequency +/-5%														
Protective method	Sealed structure (JEM1030) IP20 *3										Open structure (JEM1030) IP00					
Cooling method	Self cooling					Forced air cooling										
Color	Munsell 5Y-8/0.5															
EMI filter	Installed							External filter (optional)								

400V series

Item		Standard specification														
Applicable motor (kW)		0.75	1.5	2.2	3.7	5.5	7.5	11	15	18.5	22	30	37	45	55	75
Rating	Type	VFA7-														
	Model	4007PL	4015PL	4022PL	4037PL	4055PL	4075PL	4110PL	4150PL	4185P	4220P	4300P	4370P1	4450P1	4550P1	4750P1
	Capacity (kVA) *1	2.0	3.0	4.0	6.5	9.5	13	19	25	28	34	46	55	69	84	110
	Rated output current (A)	2.5	4.0	5.0	8.5	13	17	25	33	37	44	60	72	90	110	144
	Rated output voltage	3phase 380 to 460V (The max. output voltage is the same as the input source voltage.)														
Electrical braking	Overload current rating	2 minutes at 150%, 0.5 seconds at 215%														
	Dynamic braking circuit	Dynamic braking circuit installed										Optional				
	Electrical braking	Dynamic braking resistor	Built-in braking resistor		Braking resistor or external braking unit (optional)											
			Rating: 120W-150Ω	Rating: 120W-100Ω												
Input Power	Voltage/frequency	Main circuit	3-phase 380 to 460V - 50/60Hz						3-phase 380 to 440V - 50Hz 380 to 460V - 60Hz							
		Control circuit *2	External circuit (optional)										Single-phase 380 to 440V - 50Hz 380 to 460V - 60Hz			
	Tolerance	Voltage +10/-15% *4, frequency +/-5%														
Protective method	Sealed structure (JEM1030) IP20 *3										Open structure (JEM1030) IP00					
Cooling method	Forced air cooling															
Color	Munsell 5Y-8/0.5															
EMI filter	Installed							External filter (optional)								

Notes) *1: Capacity is calculated at 220V for the 200V models and at 440V for the 400V models
*2: An option is required for the 22kW and smaller models to be compatible with the control power supply (RO or SO).
*3: Each model has three through-holes for wiring of the main input circuit, main output circuit and control circuit. Seal them properly after wiring.
*4: +/-10% when the inverter is used continuously (load of 100%)



Noise filter inside
200V class 0.4 to 7.5kW models
400V class 0.75 to 15kW models

Standard specifications (large-capacity models)

200V series

Item		Standard specification	
Applicable motor (kW)		75	90
Rating	Type	VFA7—	
	Model	2750P1	2900P1
	Capacity (kVA) *1	110	133
	Rated output current (A)	288	350
	Rated output voltage	3phase 200 to 230V (The max. output voltage is the same as the input source voltage.)	
Overload current rating	1 minute at 150%, 0.3 seconds at 180%		
Electrical braking	Dynamic braking	Built-in braking resistor drive circuit (optional)	
	Dynamic braking resistor	External braking resistor (optional)	
Input Power Voltage/freq	Main circuit	3phase 200 to 230V - 50/60Hz	
	Control circuit	Single-phase 200 to 230V - 50/60Hz	
Tolerance	Voltage +10/-15% *2, frequency +/-5%		
Protective method	Open structure (JEM1030) IPO0		
Cooling method	Forced air cooling		
Color	Front cover/main unit cover: Munsell 5Y-8/0.5		
EMI filter	External EMI filter (optional)		

400V series

Item		Standard specification				
Applicable motor (kW)		90/110	132	160	220	280
Rating	Type	VFA7—				
	Model	4110KP1	4132KP1	4160KP1	4220KP1	4280KP1
	Capacity (kVA) *1	160	194	236	320	412
	Rated output current (A)	210	255	310	420	540
	Rated output voltage	3phase 380 to 460V (The max. output voltage is the same as the input source voltage.)				
Overload current rating	1 minute at 150%, 0.3 seconds at 180%					
Electrical braking	Dynamic braking	Built-in braking resistor drive circuit (optional)				
	Dynamic braking resistor	External braking resistor (optional)				
Input Power Voltage/freq	Main circuit	3phase 380 to 460V - 50/60Hz				
	Control circuit	Single-phase 380 to 460V - 50/60Hz				
Tolerance	Voltage +10/-15% *2, frequency +/-5%					
Protective method	Open structure (JEM1030) IPO0					
Cooling method	Forced air cooling					
Color	Front cover/main unit cover: Munsell 5Y-8/0.5					
EMI filter	External EMI filter (optional)					

Notes) *1: Capacities is calculated at 220V for the 200V models and at 440V for the 400V models
*2: +/-10% when the inverter is used continuously (load of 100%)

Specifications comparison between small/middle-capacity models and large-capacity models (differences only)

Item	Small- and middle-capacity models				Large-capacity models
	VFA7-2004PL~2150P VFA7-4007PL~4150PL	VFA7-2185P~2300P VFA7-4185P~4300P	VFA7-2370P1~2450P1 VFA7-4370P1~4550P1	VFA7-2550P1 VFA7-4750P1	VFA7-2750P1~2900P1 VFA7-4110KP1~4280KP1
1. Overload current rating	2 minutes at 150%, 0.5 seconds at 215%	2 minutes at 150%, 0.5 seconds at 215%	2 minutes at 150%, 0.5 seconds at 215%	2 minutes at 150%, 0.5 seconds at 215%	1 minute at 150% 0.3 seconds at 180%
2. PWM carrier frequency	Default: 12kHz, adjustable in a range of 0.5 to 15kHz	Default: 12kHz, adjustable in a range of 0.5 to 15kHz	Default: 8kHz, adjustable in a range of 0.5 to 15kHz	Default: 2.2kHz, adjustable in a range of 0.5 to 8kHz	Default: 2.2kHz, adjustable in a range of 0.5 to 5kHz
3. Acceleration/deceleration time (factory default setting)	10 seconds	30 seconds	30 seconds	2550P1: 30 seconds 4750P1: 60 seconds	60 seconds

General specifications

Item	Standard specification	
Control method	Sinusoidal PWM control	
Output voltage adjustment	Main circuit voltage feedback control (Automatic regulation, "fixed" and "control off" selections possible)	
Output frequency range	0.01 to 400Hz, set to 0.01 to 80Hz by default, max. frequency adjustable from 30 to 400Hz	
Frequency setting resolution	0.01Hz: operation panel input (60Hz base), 0.015Hz: analog input (60Hz base, 12/16 bit/0-10Vdc)	
Frequency precision	+/-0.2% of the max. output frequency (25+/-10°C): analog input, +/-0.01% (25+/-10°C): digital input	
Voltage/frequency characteristic	Constant V/f, variable torque, automatic torque boost, vector control and automatic energy-saving control, base frequency 1·2·3·4 adjustment (25 to 400Hz) arbitrary V/f 5-point settings, torque boost adjustment (0 to 30%), start-up frequency adjustment (0 to 10Hz), end frequency adjustment (0 to 30Hz)	
Frequency setting signal	3kΩ potentiometer (1 to 10kΩ-potentiometer connection also possible), 0 to 10Vdc (input impedance Zin: 33kΩ), 0 to +/-10Vdc (Zin: 67kΩ), 4 to 20mAdc (Zin: 500Ω)	
Terminal board reference frequency input	2 sources can be set from a total of seven types, including analog input (RR, VI, II, RX, RX2), pulse and binary/BCD (*RX2 and binary/BCD: optional)	
Frequency jump	Can be set in three places, jump frequency and band setting	
Upper/lower limit frequencies	Upper limit frequency: 0 to maximum frequency, lower limit frequency: 0 to upper limit frequency	
PWM carrier frequency selections	Adjustable within a range of 0.5 to 15kHz (0.5 to 8kHz for 200V-55kW model and 400V-75kW model)	
PID control	proportional gain, integral time, anti-hunting gain, filter delay adjustments	
Torque control *5	Current control reference: DCO to +/-10V	
Acceleration/deceleration time	0.01 to 6000 sec., acceleration/deceleration time selectable from among 1, 2, 3 and 4, automatic acceleration/deceleration function, S-pattern accel eration/deceleration patterns 1 and 2 adjustment	
DC injection braking	Braking start frequency: adjustment (0 to 120Hz), braking current adjustment: (0 to 100%), braking time adjustment: (0 to 10 sec.), emergency stop braking function, motor shaft stationally control function	
Forward/reverse run *1	Forward run F-CC "closed", reverse when R-CC "closed", reverse when both "closed" coast stop when ST-CC "opened", Emergency stop from panel or terminal block	
Jog run *1	Jog run from panel with JOG mode selection. Terminal block operation possible with parameter settings.	
Preset-speed operation *1	Set frequency +15-speed preset speeds possible with open/close combinations. S1, S2, S3, S4 and CC Acceleration/deceleration time, torque limit and V/f selectable on a frequency	
Retry	When a protective function activities, after main circuit devices are checked, running restarts. Settable to a max. of 10times.	
Soft-stall	Automatic load reduction control during overload (Default setting: OFF)	
Cooling fan ON/OFF	Fan is automatically stopped, When not necessary to ensure to extended life time.	
Panel key operation ON/OFF switching	Prahbit functions such as resetonly or monitor only etc., can be sclelected. All key operations can be also prohibit. A protection reset function which requires special operation to enable it is available.	
Regenerative power ride-through control	Operation is continued even during momentary power failure using regenerative energy from the motor. (Default setting: OFF)	
Auto-restart in	The motor can be restarted at the same speed in the same direction it run under no-load conditions before stop. (Default setting: OFF)	
Simple pattern run	32 patterns in 4 groups (8 pattern in each group) can be set according to 15-speed operation frequency. Up to 32 patterns of operation, control from terminal board/repeated operation possibl.	
Commercial power/inverter switching	Power supply to motor, switchable between commercial power and inverter	
High-speed run at low-load	With this function, the load applied to the motor can be monitored. Its rotating speed is increased to improve the operation efficiency when the load applied to it is low.	
Drooping function	This function prevent a load from being imposed to a single inverter because of imbalance, when more than one inverter is used in combination to drive the load.	
Override function	Preset frequency control value adjustable by signals from an external control unit	
Protection	Protective function	Stall prevention, current limit, overcurrent, overvoltage, load-side short-circuit, load-side ground fault, undervoltage, momentary power failure (15ms or longer), regeneration power ride-through control, electronic thermal overload protection, armature overcurrent during start-up, load-side overcur rent during start-up, dynamic braking resistor overload, heat sink overheat, emergency stop
	Electronic thermal characteristic	Standard motor/constant-torque VF motor switching, electronic thermal stall prevention operational level adjustment
Reset	Reset	Reset triggered by closing 1a-contact (or opening 1b-contact), by control panel operation, or by turning on the power after turning off temporarily.
	Tripped state retention and clear settings	
Display functions	4-digit 7-segment LED	Warning message Fault causes Monitoring function
	Selectable unit display	Can select frequency display to match moter speed, line speed, etc. Selection of display of current in amperes/%, voltage involtage/%.
	Edit function	Parameters different from those set by default are retrieved automatically, so that parameters changed can be detected easily.
	User settings initialization	Original parameters set by user can be stored. Parameters stored can be reset to original user-defined parameters.
	LED	Charge indicator Indicates that main circuit capacitors are charged.
Input/output terminal logic switching	A-contact/B-contact switchable by making a selection from the programmable I/O terminal function menu. *1, *2 (Default setting: A-contact)	
Sink/source switching	Common control terminal switchable between minus (CC) and plus (P24) (Default setting: minus common(CC))	
Output signals	Fault detection signal	1c contact output (250Vac-2A-cosφ = 1, 250Vac-1A-cosφ = 0.4, 30Vdc-1A)
	Low-speed/speed reach signal output *2	Open-collector output (24Vdc, Max. 50mA, output impedance: 33Ω)
	Upper/lower limit frequency output *2	Open-collector output (24Vdc, Max. 50mA, output impedance: 33Ω)
	Frequency meter output/ammeter output *3	Analog output, 1mAdc full-scale ammeter or 7.5Vdc-1mA voltmeter
Pulse train frequency output	Open-collector output (24Vdc, Max. 50mA)	
Communication functions	RS485 equipped as standard (connector: modular 8P, optional device required for communication with more than one unit) RS232C TOSLINE-F10M, TOSLINE-S20 optional. DeviceNet and Profibus are on the drawing board.	
Service conditions	Service environment	Indoor, altitude 1000m or less, not subject to direct sunlight or corrosive/explosive gas or steam
	Ambient temperature	-10 to +50°C (Max. 50°C, provided that the upper cover is removed when the ambient temperature exceeds 40°C.) *4, *5
	Storage temperature	-25 to +65°C
	Relative humidity	20 to 93% (no condensation allowed)
	Vibration	5.9m/s ² or less (10 to 55Hz) (according to JIS C0040)

Notes)

*1. The 16 contact-input terminals (8 of which are optional) are programmable. For each of them, a signal can be selected from among 136 signals.

*2. For each programmable ON/OFF output terminal, a signal can be selected from among 119 signals.

*3. For each programmable analog output terminal, a signal can be selected from among 32 signals.

*4. When the cover is removed, the unit must be placed in the panel to prevent the charger from being exposed. For the 18.5kW and larger models, the unit can be used in a temperature range of -10 to +50°C with the cover left attached.

*5. Sensorless vector control mode disable to torque control at low load or low speed. Vector control with sensor enable to high precision control.

*6. In case of the ambient temperature from 40°C to 50°C, derate the load to 80% for -2150P and to 85% for -4150PL.

*7. The inverter is protected from over current by ground fault on the output side.

External dimensions

Outline drawing

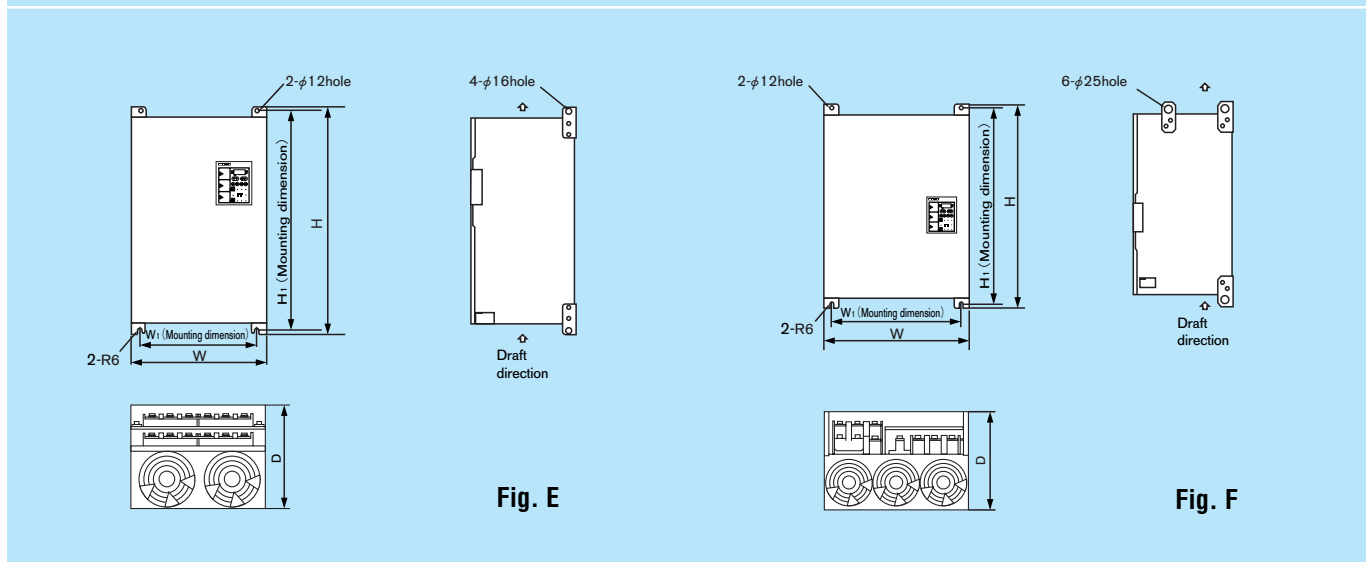
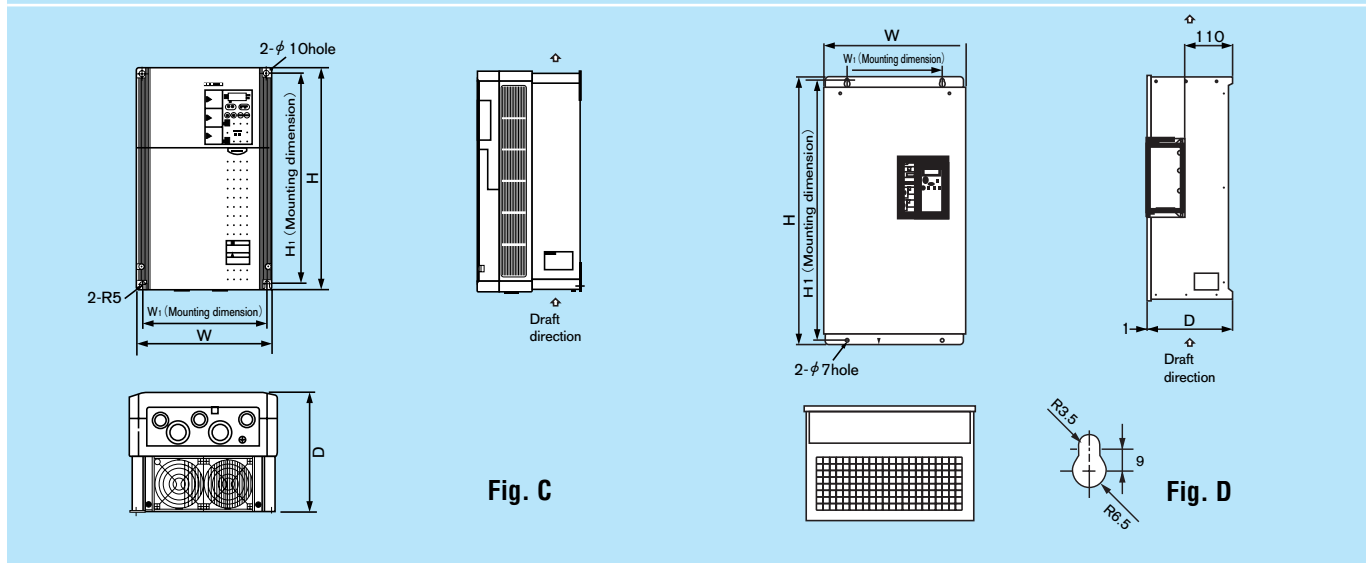
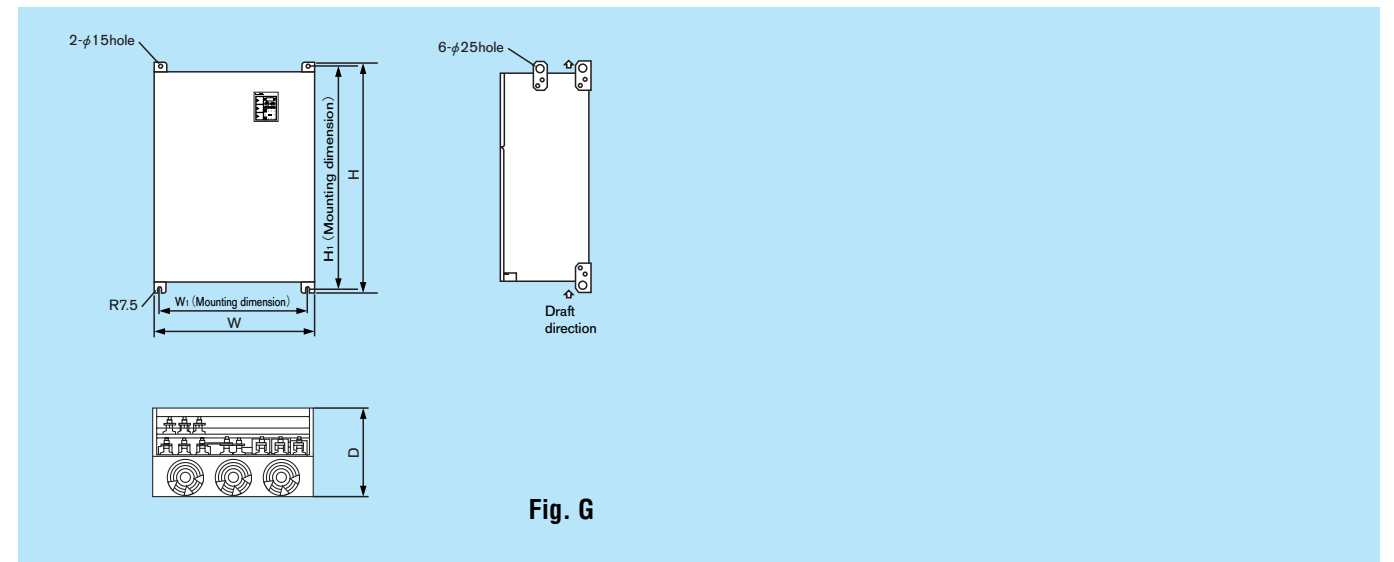
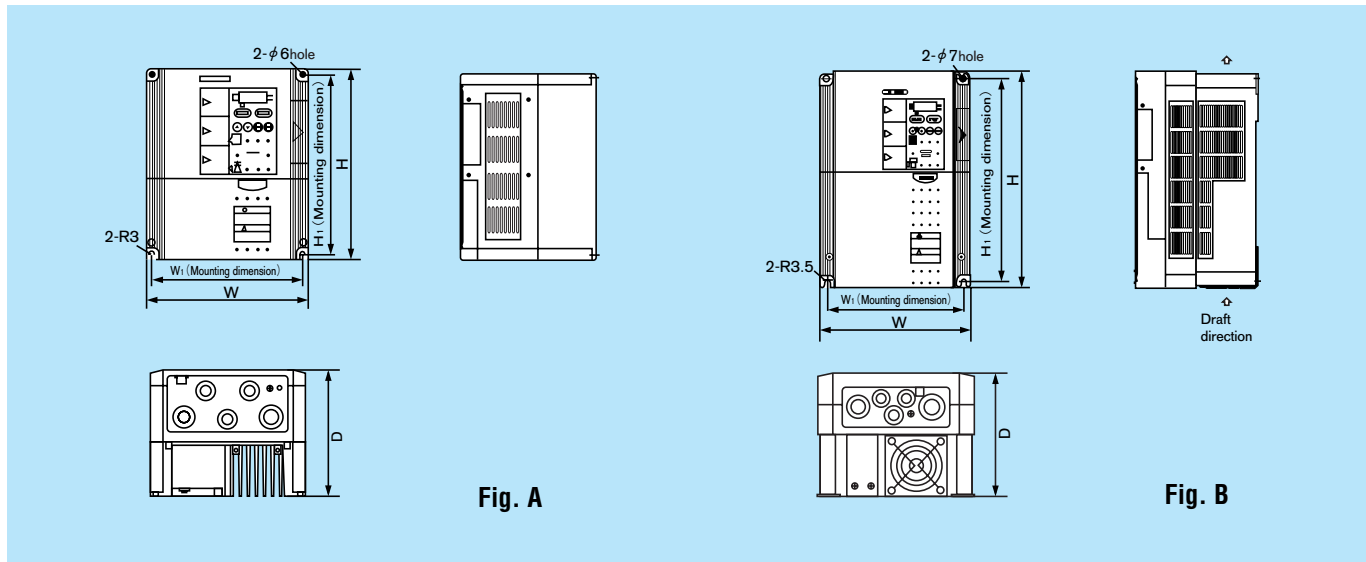

External dimensions/weights

Voltage class	Applicable motor capacity (kW)	Inverter type	Dimensions (mm)					External dimensions drawing	Approx. weight (kg)
			W	H	D	W _i	H _i		
200V	0.4	VFA7-2004PL	185	215	155	171	202	A	3.5
	0.75	VFA7-2007PL							3.5
	1.5	VFA7-2015PL							3.6
	2.2	VFA7-2022PL							4.0
	3.7	VFA7-2037PL	210	300	173	190	280	B	4.1
	5.5	VFA7-2055PL							6.6
	7.5	VFA7-2075PL							7.0
	11	VFA7-2110P	245	390	190	225	370	C	11
	15	VFA7-2150P							15.4
	18.5	VFA7-2185P			207				15.4
	22	VFA7-2220P			207				15.4
	30	VFA7-2300P	300	555	197	200	537	D	22.5
	New 37	VFA7-2370P1	370	630	290	317.5	609	E	44
	New 45	VFA7-2450P1							46
New 55	VFA7-2550P1	46							
New 75	VFA7-2750P1	480	680	330	426	652	F	72	
New 90	VFA7-2900P1	660	950	370	598	920	G	148	
400V	0.75	VFA7-4007PL	185	215	155	171	202	A	3.5
	1.5	VFA7-4015PL							3.6
	2.2	VFA7-4022PL							3.9
	3.7	VFA7-4037PL							4.1
	5.5	VFA7-4055PL	210	300	173	190	280	B	7.0
	7.5	VFA7-4075PL							7.1
	11	VFA7-4110PL							11
	15	VFA7-4150PL	245	390	190	225	370	C	11
	18.5	VFA7-4185P							15.4
	22	VFA7-4220P			207				15.4
	30	VFA7-4300P			207				15.4
	30	VFA7-4300P	300	555	197	200	537	D	24
	New 37	VFA7-4370P1	370	630	290	317.5	609	E	47
	New 45	VFA7-4450P1							48
	New 55	VFA7-4550P1							48
	New 75	VFA7-4750P1	480	680	330	426	652	F	49
	New 90/110	VFA7-4110KP1							75
	New 132	VFA7-4132KP1							77
	New 160	VFA7-4160KP1	660	950	370	598	920	G	159
	New 220	VFA7-4220KP1							166
New 280	VFA7-4280KP1	168							

Basic and extended parameters

Basic parameters

Basic parameters refer to parameters which need to be set before the first use after purchasing the inverter. Among these parameters are the parameters of acceleration/deceleration times, preset-speed operation, motor control selection.

Title	Function	Adjustment range	Default setting
AU1	Automatic acceleration/deceleration	0: Manual acceleration/deceleration 1: Automatic acceleration/deceleration	0
AU2	Automatic V/f mode setting	0: - 1: Automatic torque boost + auto-tuning 2: Sensorless vector control (speed) + auto-tuning 3: Automatic energy-saving + auto-tuning	0
CNOd	Operation command mode selection	0: Terminal block enabled 1: Operating panel enabled 2: Common serial communication option 3: Serial communication RS485 4: Communication add-on option enabled	0
FNOd	Speed setting mode selection	1: VI (voltage input)/II (current input) 2: RR (Potentiometer/voltage input) 3: RX (voltage input) 4: RX2 (voltage input) (optional) 5: Operating panel input enabled 6: Binary/BCD input 7: Common serial communication option 8: Serial communication RS485 9: Communication add-on module option 10: Up-down frequency 11: Pulse input 1 (PG feed back option)	2
FNSL	Selection of meter connected to FM terminal	0 to 32	0
FN	Connected meter adjustment of FM terminal	—	—
LYP	Standard setting mode selection	0: - 1: 50Hz standard setting 2: 60Hz standard setting 3: Factory default setting 4: Trip clear 5: Clearing accumulating operation time 6: Initialization of type form 7: Memorization of user-defined parameters 8: Reset of user-defined parameters	0
Fr	Forward/reverse selection (At panel control only)	0: Forward, 1: Reverse	0
ACC	Acceleration time #1	0.1(F508)~6000 [sec.]	Model dependent
DEC	Deceleration time #1	0.1(F508)~6000 [sec.]	Model dependent
FH	Maximum frequency	30.0~400 [Hz]	80
UL	Upper limit frequency	0.0~FH [Hz]	80
LL	Lower limit frequency	0.0~UL [Hz]	0.0
UL	Base frequency #1	25~400 [Hz]	60
Pt	Motor control mode selection	0: Constant torque 1: Variable torque mode 2: Automatic torque boost 3: Sensorless vector control (speed) 4: Automatic torque boost + automatic energy-saving 5: Sensorless vector control (speed) + automatic energy-saving 6: V/f 5-points setting 7: Sensorless vector control (speed/torque switching) 8: PG feedback vector control (speed/torque switching) 9: PG feedback vector control (speed/position switching)	0
LB	Manual torque boost #1	0~30 [%]	Model dependent
OLN	Selection of electronic thermal protection characteristics	Setting	OL stall
		0	valid
		1	invalid
		2	valid
		3	invalid
		4	valid
		5	invalid
		6	valid
7	invalid		
SR1	Preset-speed #1	LL~UL [Hz]	0.0
SR2	Preset-speed #2	LL~UL [Hz]	0.0
SR3	Preset-speed #3	LL~UL [Hz]	0.0
SR4	Preset-speed #4	LL~UL [Hz]	0.0
SR5	Preset-speed #5	LL~UL [Hz]	0.0
SR6	Preset-speed #6	LL~UL [Hz]	0.0
SR7	Preset-speed #7	LL~UL [Hz]	0.0
F1	Extended parameter	Setting of extended parameters listed on the following pages	—
F9			
Gr.U	Automatic edit function	Displays parameters differ from the standard setting values.	—

Extended parameters

Extended parameters are used to for detailed setting.

Title	Function	Adjustment range	Default setting
F100	Low-speed signal output frequency	0.0~UL [Hz]	0.0
F101	Speed reach setting frequency	0.0~UL [Hz]	0.0
F102	Speed reach detection band	0.0~UL [Hz]	2.5
F103	ST (standby) signal selection	0: standard, 1: Always ON, 2: Linked with F/R terminals	0
F105	Priority selection (both F-CC, R-CC is ON)	1: Reverse, 1: Stop	0
F106	Priority setting of input terminal	0: Disabled, 1: Enabled	0
F107	Binary/BCD signal selection (Extended terminal add-on cassette option)	0: None	5: Reverse 12-bit binary input
		1: 12-bit binary code	6: Reverse 16-bit binary input
		2: 16-bit binary code	7: Reverse 3-digit BCD input
		3: 3-digit BCD code	8: Reverse 4-digit BCD input
F108	Up-down frequency	0~7	0

Title	Function	Adjustment range	Default setting
F110	Always active function selection	0~135	0
F111	Input terminal selection #1 (F)	0~135	2(F)
F112	Input terminal selection #2 (R)	0~135	4(R)
F113	Input terminal selection #3 (ST)	0~135	6(ST)
F114	Input terminal selection #4 (RES)	0~135	8(RES)
F115	Input terminal selection #5 (S1)	0~135	10(S1)
F116	Input terminal selection #6 (S2)	0~135	12(S2)
F117	Input terminal selection #7 (S3)	0~135	14(S3)
F118	Input terminal selection #8 (S4)	0~135	16(S4)
F119	Input terminal selection #9	0~135	0
F120	Input terminal selection #10	0~135	0
F121	Input terminal selection #11	0~135	0

Extended parameters

Title	Function	Adjustment range	Default setting			
Selection of terminal function	F122	Input terminal selection #12	0~135	0		
	F123	Input terminal selection #13	0~135	0		
	F124	Input terminal selection #14	0~135	0		
	F125	Input terminal selection #15	0~135	0		
	F126	Input terminal selection #16	0~135	0		
	F130	Output terminal selection #1 (OUT1)	0~119	4(LOW)		
	F131	Output terminal selection #2 (OUT2)	0~119	6(RCH)		
	F132	Output terminal selection #3 (FL)	0~119	10(FL)		
	F133	Output terminal selection #4	0~119	0		
	F134	Output terminal selection #5	0~119	2		
	F135	Output terminal selection #6	0~119	8		
	F136	Output terminal selection #7	0~119	14		
	Terminal response time setting	F140	Input terminal #1 response time Selection(F)	2 to 200 [msec.] (in steps of 2.5 ms)	8	
		F141	Input terminal #2 response time Selection(R)	2 to 200 [msec.] (in steps of 2.5 ms)	8	
		F142	Input terminal #3 response time Selection(ST)	2 to 200 [msec.] (in steps of 2.5 ms)	8	
		F143	Input terminal #4 response time Selection(RES)	2 to 200 [msec.] (in steps of 2.5 ms)	8	
F144		Input terminal #5-6 response time Selection	2 to 200 [msec.] (in steps of 2.5 ms)	8		
F145		Input terminal #9-16 response time Selection	2 to 200 [msec.] (in steps of 2.5 ms)	8		
F150		Output terminal #1 delay time (OUT1)	2 to 200 [msec.] (in steps of 2.5 ms)	2		
F151		Output terminal #2 delay time (OUT2)				
F152		Output terminal #3 delay time (FL)				
F153		Output terminal #4 delay time				
F154		Output terminal #5 delay time				
F155		Output terminal #6 delay time				
F156		Output terminal #7 delay time				
F160		Output terminal #1 holding time (OUT1)				
F161		Output terminal #2 holding time (OUT2)				
F162		Output terminal #3 holding time (FL)				
F163	Output terminal #4 holding time					
F164	Output terminal #5 holding time					
F165	Output terminal #6 holding time					
F166	Output terminal #7 holding time					
Basic parameters 2	F170	Base frequency 2			25~400 [Hz]	60
	F171	Base frequency voltage 2			0~600[V]	Model dependent
	F172	Manual torque boost 2	0~30[%]	Model dependent		
	F173	Motor overload protection level 2	10~100[%]	100		
	F174	Base frequency 3	25~400 [Hz]	60		
	F175	Base frequency voltage 3	0~600[V]	Model dependent		
	F176	Manual torque boost 3	0~30[%]	Model dependent		
	F177	Motor overload protection level 3	10~100[%]	100		
	F178	Base frequency 4	25~400 [Hz]	60		
	F179	Base frequency voltage 4	0~600[V]	Model dependent		
	F180	Manual torque boost 4	0~30[%]	Model dependent		
	F181	Motor overload protection level 4	10~100[%]	100		
	F182	Motor switching mode selection	0: Standard, 1: Customizd	0		
	F183	V/f adjustment coefficient	0~255	32		
	F190	V/f 5-point setting VF1 frequency	0.0~400[Hz]	0		
	F191	V/f 5-point setting VF1 voltage	0~100[%]	0		
F192	V/f 5-point setting VF2 frequency	0.0~400[Hz]	0			
F193	V/f 5-point setting VF2 voltage	0~100[%]	0			
F194	V/f 5-point setting VF3 frequency	0.0~400[Hz]	0			
F195	V/f 5-point setting VF3 voltage	0~100[%]	0			
F196	V/f 5-point setting VF4 frequency	0.0~400[Hz]	0			
F197	V/f 5-point setting VF4 voltage	0~100[%]	0			
F198	V/f 5-point setting VF5 frequency	0.0~400[Hz]	0			
F199	V/f 5-point setting VF5 voltage	0~100[%]	0			
F200	Reference priority selection	0:FMOd1:F207, 2:FMOd priority, 3:F207 priority, 4:FMOdF207 switching	0			
F201	VI/II reference point #1	0~100[%]	20			
F202	VI/II reference point #1 frequency	0~FH [Hz]	0			
F203	VI/II reference point #2	0~100[%]	100			
F204	VI/II reference point #2 frequency	0~FH [Hz]	80.0			
F205	VI/II reference point #1 %	0~250[%] (For torque control)	0			
F206	VI/II reference point #2 %	0~250[%] (For torque control)	100			
F207	Speed setting mode selection #2	Same as FNOd (1 to 11)	1			
F208	FMOd/F207 switching frequency	0.1~FH [Hz]	1.0			
F209	Analog input filter	0 (disabled) to 3 (max. filter capacity)	0			
F210	RR reference point #1	0~100[%]	0			
F211	RR point #1 frequency	0~FH [Hz]	0.0			
F212	RR reference point #2	0~100[%]	100			
F213	RR point #2 frequency	0~FH [Hz]	80.0			
F214	RR point #1 rate	0~250[%] (For torque control)	0			
F215	RR point #2 rate	0~250[%] (For torque control)	100			
F216	RX reference point #1	-100~100[%]	0.0			
F217	RX point #1 frequency	-FH~FH [Hz]	0.0			
F218	RX reference point #2	-100~100[%]	100			
F219	RX point #2 frequency	-FH~FH [Hz]	80.0			
F220	RX reference point #1 rate	-250~250[%] (For torque control)	0			
F221	RX reference point #2 rate	-250~250[%] (For torque control)	100			
F222	RX 2 reference point #1	-100~100[%]	0.0			
F223	RX 2 point #1 frequency	-FH~FH [Hz]	0			
F224	RX 2 reference point #2	-100~100[%]	100			
F225	RX 2 point #2 frequency	-FH~FH [Hz]	80.0			
F226	RX 2 reference point #1 rate	-250~250[%] (For torque control)	0			
F227	RX 2 reference point #2 rate	-250~250[%] (For torque control)	100			
F228	BIN 2 reference point #1	0~100[%]	0.0			
F229	BIN point #1 frequency	-FH~FH [Hz]	0.0			
F230	BIN reference point #2	0~100[%]	100			
F231	BIN point #2 frequency	-FH~FH [Hz]	80.0			
F232	BIN reference point #1 rate	-250~250[%] (For torque control)	0			
F233	BIN reference point #2 rate	-250~250[%] (For torque control)	100			
F234	Pulse reference point #1	-100~100[%]	0.0			

Title	Function	Adjustment range	Default setting		
Speed and torque command gain/bias settings	F235	Pulse point #1 frequency	-FH~FH [Hz]	0.0	
	F236	Pulse reference point #2	-100~100[%]	100	
	F237	Pulse point #2 frequency	-FH~FH [Hz]	80.0	
	F240	Start-up frequency setting	0.0~10[%]	0.1	
	F241	Run frequency setting	0.0~FH [Hz]	0.0	
	F242	Run frequency hysteresis	0.0~30[Hz]	0.0	
	F243	End frequency setting	0.0~30[Hz]	0.0	
	F244	Dead band of 0Hz frequency setting signal	0~5[Hz]	0	
	F250	DC injection braking start frequency	0.0~120[Hz]	0.0	
	F251	DC injection braking current	0~100[%]	50	
Start/end frequencies	F252	DC injection braking time	0.0~10.0[sec.]	1.0	
	F253	Forward/reverse DC braking priority control	0:OFF, 1:ON	0.0	
	F254	Motor shaft fixing control	0:Disabled 1:Enabled	0.0	
	F255	Output function of 0Hz command for stop	0:Standard(DC injection braking) 1:0[Hz] command	0	
	F260	Jog run frequency	0.0~20[Hz]	0	
	DC injection braking	F261	Jog stop control	0: Deceleration stop, 1: Coast stop, 2: DC injection braking stop	0.0
		F270	Jump frequency #1	0.0~FH [Hz]	0.0
	Jog	F271	Jump frequency band #1	0.0~30[Hz]	0.0
		F272	Jump frequency #2	0.0~FH [Hz]	0.0
		F273	Jump frequency band #2	0.0~30[Hz]	0.0
F274		Jump frequency #3	0.0~FH [Hz]	0.0	
F275		Jump frequency band #3	0.0~30[Hz]	0.0	
F276		Object of jump frequency process	0: process amount, 1: output frequency	1	
F277		Preset-speed frequency #8	LL~UL [Hz]	0.0	
F278		Preset-speed frequency #9	LL~UL [Hz]	0.0	
F279		Preset-speed frequency #10	LL~UL [Hz]	0.0	
F280		Preset-speed frequency #11	LL~UL [Hz]	0.0	
Jump frequency	F281	Preset-speed frequency #12	LL~UL [Hz]	0.0	
	F282	Preset-speed frequency #13	LL~UL [Hz]	0.0	
	F283	Preset-speed frequency #14	LL~UL [Hz]	0.0	
	F284	Preset-speed frequency #15	LL~UL [Hz]	0.0	
	Preset-speed frequencies	F300	PWM carrier frequency	0.5~15.0(8.0, 5.0)[kHz] Model dependent	Model dependent
		F301	Auto-restart (motor speed search)	0: Disabled, 1: Available at power failure, 2: ST ON/OFF, 3: 1+2	0
		F302	Regenerative power ride-through control/Deceleration time	0: OFF, 1: ON, 2: ON(Deceleration stop)	0
		F303	Retry selection	0: Disabled, 1 to 10 times	0
		F304	Dynamic braking mode selection	0: Disabled, 1: Enabled/overload detection enabled	Model dependent
		F305	Over voltage stall protection	0: Disabled, 1: Enabled, 2: Enabled (Forced shorted deceleration)	0
F306		Voltage of base frequency (output voltage adjustment)	0~600[V]	Model dependent	
F307		Selection of base frequency voltage (Voltage compensation)	1: with voltage compensation (output voltage not limited) 2: without voltage compensation (output voltage limited) 3: with voltage compensation (output voltage limited)	1	
F308		PBR resistance	1.0~1000[Ω]	Model dependent	
F309		PBR resistor capacity	0.01~600[kW]	Model dependent	
PWM Carrier frequency	F310	Ride-through time/Deceleration time	0.0~320 [sec.]	2.0	
	F311	Reverse-run prohibition selection	0: All directions permitted 1: Reverse run prohibited 2: Forward run prohibited 3: Direction designated by command permitted	0	
	F312	Auto-restart adjustment parameter 1	0.5~2.5	Model dependent	
	F313	Auto-restart adjustment parameter 2	0.5~2.5	Model dependent	
	F314	Auto-restart mode selection	0~4	Model dependent	
	F315	Auto-restart adjustment parameter 3	0~9	1	
	F320	Drooping gain	0.00~100[%] (Enabled if Pt = 7, 8 or 9)	0	
	F321	Speed at drooping gain 0%	0.0~320[Hz] (Enabled if Pt = 7, 8 or 9)	60	
	F322	Speed at drooping gain F320	0.0~320[Hz] (Enabled if Pt = 7, 8 or 9)	60	
	F323	Drooping insensitive torque band	0.00~100[%] (Enabled if Pt = 7, 8 or 9)	10	
F324	Output filter for drooping	0.1~200 [sec.]	100		
Triplex enhancement settings	F325	Load inertia(Acc/Dec torque)	0~1000	1.0	
	F326	Load torque filter(Acc/Dec torque)	0.0~199.9, 200.0: without filter	200.0	
	F327	Drooping reference selection	0: Torque monitor 1: Same as 0 [®] 2: Torque reference 3: Same as 2 [®] ※Without Acc/dec torque removal	0	
	F330	Selection of high-speed operation at low-load	0~5	0	
	F331	Lower limit frequency for low-load high-speed operation switching	30~UL [Hz]	40	
	F332	Load detection delay time during low-load high-speed operation	0.0~10.0 [sec.]	1.0	
	F333	Load detection time during low-load high-speed operation	0.0~10.0 [sec.]	1.0	
	F334	Heavy load detection time during low-load high-speed operation	0.0~10.0 [sec.]	5.0	
	F335	Switching load torque during forward run	0.00~250[%]	50	
	F336	Heavy load torque during acceleration in forward direction	0.00~250[%]	150	
Speed and torque command gain/bias settings	F337	Heavy load torque during deceleration in forward direction	0.00~250[%]	100	
	F338	Switching load torque during reverse run	0.00~250[%]	50	
	F3				

Extended parameters

	Title	Function	Adjustment range	Default setting
PID control	F360	Signal selection of PID control	0: PID control disabled, 1: V/II, 2: RR, 3: RX, 4: RX2	0
	F361	Delay filter	0~255	0
	F362	Proportional (P) gain	0.01~100	0.1
	F363	Integral (I) gain	0.01~100	0.1
	F364	PID deviation upper limit	0~50[%]	50
	F365	PID deviation lower limit	0~50[%]	50
	F366	Differential (D) gain	0.0~25.5	0.0
	F367	Number of PG input pulses	1 to 9999 [pulse/revolution]	500
	F368	Selection of number of PG input phases	1: Single-phase input, 2: Two-phase input	2
	F369	PG disconnection detection selection	0: Disabled, 1: Enabled	0
Speed feedback/positioning control	F370	Electronic gear	100~4000 Pulses/Rotation	1000
	F371	Position loop gain	0.0~100.0	4.0
	F372	Positioning completion range	1~4000	100
	F373	Frequency limit at position control	1~8000, 8001: Disabled	800
	F374	Current control proportional gain	100~1000	209.1
	F375	Current control integral gain	100~1250	Model dependent
	F376	Speed loop proportional gain	3.2~1000	Model dependent
	F377	Speed loop integral gain	0.1~200.0[rad/sec.]	Model dependent
	F378	Motor counter data selection	0~5	0
	F379	Speed loop parameter ratio	0.01~10.00[s]	1.00
Preset-speed operation mode	F380	Selection of preset-speed operation mode	0: Non-mode preset speed, 1: Preset speed by mode	0
	F381	Preset-speed operation frequency #1 control mode	0: Forward run +1: Reverse run +2: Selection of acceleration/deceleration 1 +4: Selection of acceleration/deceleration 2 +8: Selection of V/f 1 +16: Selection of V/f 2 +32: Selection of torque limit 1 +64: Selection of torque limit 2	0
	F382	Preset-speed operation frequency #2 control mode	Ditto	0
	F383	Preset-speed operation frequency #3 control mode	Ditto	0
	F384	Preset-speed operation frequency #4 control mode	Ditto	0
	F385	Preset-speed operation frequency #5 control mode	Ditto	0
	F386	Preset-speed operation frequency #6 control mode	Ditto	0
	F387	Preset-speed operation frequency #7 control mode	Ditto	0
	F388	Preset-speed operation frequency #8 control mode	Ditto	0
	F389	Preset-speed operation frequency #9 control mode	Ditto	0
Torque Control	F390	Preset-speed operation frequency #10 control mode	Ditto	0
	F391	Preset-speed operation frequency #11 control mode	Ditto	0
	F392	Preset-speed operation frequency #12 control mode	Ditto	0
	F393	Preset-speed operation frequency #13 control mode	Ditto	0
	F394	Preset-speed operation frequency #14 control mode	Ditto	0
	F395	Preset-speed operation frequency #15 control mode	Ditto	0
	F396	Torque command filter 2	0~100	0
	F397	Speed loop proportional gain2	3.2~1000	Model dependent
	F398	Speed loop integral gain2	0.1~200.0[rad/sec.]	Model dependent
	Motor constant	F400	Auto-tuning selection	0: Without auto-tuning (internal table) 1: Motor constant initialization 2: Auto-tuning execution (O after executed)
F401		Slip frequency gain	0.0~2.55	0.6
F402		Motor constant 1 (primary resistance)	0.0~100000[mΩ]	Model dependent
F403		Motor constant 2 (secondary resistance)	0.0~100000[mΩ]	Model dependent
F404		Motor constant 3 (exciting inductance)	0.0~6500[mH]	Model dependent
F405		Motor constant 4 (load inertia moment)	0.0~100.0	1.0
F410		Motor constant 5 (leak inductance)	0.0~650.0[mH]	Model dependent
F411		Number of poles of motor	2, 4, 6, 8, 10, 12, 14, 16 [pole]	4
F412		Rated capacity of motor	0.1~Model dependent [kW]	Model dependent
F413		Motor type	0: Toshiba standard motor #1 1: Toshiba VF motor 2: Toshiba V3 motor 3: Toshiba standard motor #2 4: Other motors	0
Torque control	F414	Selection of auto-tuning 2	0: Disabled 1: Executed(sensorless rector control) 2: Executed(vector control with sensor)	1
	F420	Torque command selection	1: V/II 2: RR 3: RX 4: RX2 5: Panel parameter 6: Binary/BCD input 7: Common communication 8: Serial communication 9: RS485 10: Communication add-on cassette option	3
	F421	Torque command filter	10~199.9, 200 (no filter)	200
	F422	Selection of synchronized torque bias input	0: Disabled, 1 to 9 (Same as F420)	0
	F423	Selection of tension torque bias input	0: Disabled, 1 to 9 (Same as F420)	0
	F424	Load sharing gain input selection	0: Disabled, 1 to 9 (Same as F420)	0
	F425	Forward speed limit input selection	0: Disabled, 1: V/II, 2: RR, 3: RX, 4: RX2, 5: F426	0
	F426	Forward speed limit level	0.0~UL	80.0
	F427	Reverse speed limit input selection	0: Disabled, 1: V/II, 2: RR, 3: RX, 4: RX2, 5: F428	0
	F428	Reverse speed limit level	0.0~UL [Hz]	80.0
Torque limit	F429	Torque command mode selection	0: Fixed direction, 1: F/R permitted	0
	F430	Selection of speed limit (torque=0) center reference	0: Disabled, 1: V/II, 2: RR, 3: RX, 4: RX2, 5: F431	5
	F431	Speed limit(torque=0) level	0~FH[Hz]	0
	F432	Speed limit(torque=0) band	0~FH[Hz]	0
	F433	Speed limit(torque=0) recovery time	0~2.5[sec]	0.2
	F440	Selection of power running torque limit #1	1: V/II, 2: RR, 3: RX, 4: RX2, 5: F441	5
	F441	Power running torque limit #1	0~249.9[%], 250: Disabled	250.0
	F442	Selection of regenerative torque limit #1	0: Disabled, 1: V/II, 2: RR, 3: RX, 4: RX2, 5: F443	5
	F443	Regenerative torque limit #1	0~249[%], 250: Disabled	250
	F444	Power running torque limit #2	0~249[%], 250: Disabled	250
F445	Regenerative torque limit #2	0~249[%], 250: Disabled	250	
F446	Power running torque limit #3	0~249[%], 250: Disabled	250	

	Title	Function	Adjustment range	Default setting
Torque limit	F447	Regenerative torque limit #3	0~249[%], 250: Disabled	250
	F448	Power running torque limit #4	0~249[%], 250: Disabled	250
	F449	Regenerative torque limit #4	0~249[%], 250: Disabled	250
	F450	Torque limit mode selection	0: Power-running/regenerative torque limit, 1: Positive/negative torque limit	
	F451	Torque limit mode	0: Standard, 1: no speed cooperation	0
	F452	Continuous stall trip detection time during power running	0.0~1.0[s]	0.0
	F453	Stall prevention during regeneration	0: Stall, 1: Stall is prevented	0
	F454	Current differential gain	0.00~327.6	123.0
	F470	V/II reference bias	0~255	99
	F471	V/II reference gain	0~255	156
Torque limit	F472	RR reference bias	0~255	100
	F473	RR reference gain	0~255	164
	F474	RX reference bias	0~255	—
	F475	RX reference gain	0~255	—
	F476	RX2 reference bias	0~255	—
	F477	RX2 reference gain	0~255	—
	F480	Exciting strengthening coefficient	0~255	64
	F481	Over-excitation cooperation	0: Enabled, 1: Applied by F480 setting	0
	F482	Modulation rate control margin(current control)	80.0~300.0[%]	90.0
	F483	Modulation rate control margin(voltage control)	80.0~300.0[%]	105.0
Acceleration/deceleration 2	F484	Modulation rate control margin(V/f control)	80.0~300.0[%]	105.0
	F485	Stall cooperation gain at field weakening zone	0~255	128
	F486	Exciting starting rate	1.64~327.6	163.8
	F487	Compensation coefficient for iron loss	0~255	10
	F488	Voltage compensation coefficient for dead time	0.00~327.6	3.90
	F489	Dead time Compensation	0: Enabled, 1: Disabled	0
	F490	Dead time Compensation(bias time)	-3.27~3.27	0.00
	F491	Current / voltage control switching frequency	10.0~60.0[Hz]	40.0
	F500	Acceleration time #2	F508 ~6000[sec.]	Model dependent
	F501	Deceleration time #2	F508 ~6000[sec.]	Model dependent
Acceleration/deceleration 2	F502	Acceleration/deceleration #1 pattern	0: Linear, 1: S-pattern 1, 2: S-pattern 2	0
	F503	Acceleration/deceleration #2 pattern	0: Linear, 1: S-pattern 1, 2: S-pattern 2	0
	F504	Panel acceleration/deceleration #1, 2, 3, 4 selection	1: Acceleration/deceleration #1 2: Acceleration/deceleration #2 3: Acceleration/deceleration #3 4: Acceleration/deceleration #4	1
	F505	ACC/Dec switching frequency #1	0.0~FH [Hz]	0
	F506	S-pattern lower-limit adjustment amount	0~50[%]	25
	F507	S-pattern upper-limit adjustment amount	0~50[%]	25
	F508	ACC/Dec time lower limit	0.01~10[sec.]	0.1
	F510	Acceleration time #3	F508 ~6000[sec.]	Model dependent
	F511	Deceleration time #3	F508 ~6000[sec.]	Model dependent
	F512	ACC/Dec #3 pattern	0: Linear, 1: S-pattern 1, 2: S-pattern 2	0
Acceleration/deceleration 2	F513	ACC/Dec switching frequency #2	0.0~FH [Hz]	0.0
	F514	Acceleration time #4	F508 ~6000[sec.]	Model dependent
	F515	Deceleration time #4	F508 ~6000[sec.]	Model dependent
	F516	Pattern #4	0: Linear, 1: S-pattern 1, 2: S-pattern 2	0
	F517	ACC/Dec switching frequency #3	0.0~FH [Hz]	0.0
	F520	Pattern run selection	0: No, 1: Yes	0
	F521	Pattern run mode	0: Patterned operation canceled during stop 1: Patterned operation continued during stop	0
	F530	Number of cycles of pattern group #1	1~254, 255:∞	1
	F531	Selection 1 of pattern group #1	0: Skip, 1 to 15	1
	F532	Selection 2 of pattern group #1	0: Skip, 1 to 15	2
Patterned operation	F533	Selection 3 of pattern group #1	0: Skip, 1 to 15	3
	F534	Selection 4 of pattern group #1	0: Skip, 1 to 15	4
	F535	Selection 5 of pattern group #1	0: Skip, 1 to 15	5
	F536	Selection 6 of pattern group #1	0: Skip, 1 to 15	6
	F537	Selection 7 of pattern group #1	0: Skip, 1 to 15	7
	F538	Selection 8 of pattern group #1	0: Skip, 1 to 15	8
	F540	Number of cycles of pattern group #2	1~254, 255:∞	1
	F541	Selection 1 of pattern group #2	0: Skip, 1 to 15	9
	F542	Selection 2 of pattern group #2	0: Skip, 1 to 15	10
	F543	Selection 3 of pattern group #2	0: Skip, 1 to 15	11
Patterned operation	F544	Selection 4 of pattern group #2	0: Skip, 1 to 15	12
	F545	Selection 5 of pattern group #2	0: Skip, 1 to 15	13
	F546	Selection 6 of pattern group #2	0: Skip, 1 to 15	14
	F547	Selection 7 of pattern group #2	0: Skip, 1 to 15	15
	F548	Selection 8 of pattern group #2	0: Skip, 1 to 15	0
	F550	Number of cycles of pattern group #3	1~254, 255:∞	1
	F551	Selection 1 of pattern group #3	0: Skip, 1 to 15	1
	F552	Selection 2 of pattern group #3	0: Skip, 1 to 15	2
	F553	Selection 3 of pattern group #3	0: Skip, 1 to 15	3
	F554	Selection 4 of pattern group #3	0: Skip, 1 to 15	4
Patterned operation	F555	Selection 5 of pattern group #3	0: Skip, 1 to 15	5
	F556	Selection 6 of pattern group #3	0: Skip, 1 to 15	6
	F557	Selection 7 of pattern group #3	0: Skip, 1 to 15	7
	F558	Selection 8 of pattern group #3	0: Skip, 1 to 15	8
	F560	Number of cycles of pattern group #4	1~254, 255:∞	1
	F561	Selection 1 of pattern group #4	0: Skip, 1 to 15	9
	F562	Selection 2 of pattern group #4	0: Skip, 1 to 15	10
	F563	Selection 3 of pattern group #4	0: Skip, 1 to 15	11
	F564	Selection 4 of pattern group #4	0: Skip, 1 to 15	12
	F565	Selection 5 of pattern group #4	0: Skip, 1 to 15	13
Patterned operation	F566	Selection 6 of pattern group #4	0: Skip, 1 to 15	14
	F567	Selection 7 of pattern group #4	0: Skip, 1 to 15	15
	F568	Selection 8 of pattern group #4	0: Skip, 1 to 15	0
	F570	Speed #1 operation continuation mode	0: Operation time in sec. after start of operation 1: Operation time in min. after start of operation 2: Operation time in sec. after attainment of frequency 3: Operation time in min. after attainment of frequency	0

Extended parameters

	Title	Function	Adjustment range	Default setting
Patterned operation	F570	Speed #1 operation continuation mode	4: Infinite (continued until stop command is entered) 5: Continued until time step command is entered	0
	F571	Speed #2 operation continuation mode	Ditto	0
	F572	Speed #3 operation continuation mode	Ditto	0
	F573	Speed #4 operation continuation mode	Ditto	0
	F574	Speed #5 operation continuation mode	Ditto	0
	F575	Speed #6 operation continuation mode	Ditto	0
	F576	Speed #7 operation continuation mode	Ditto	0
	F577	Speed #8 operation continuation mode	Ditto	0
	F578	Speed #9 operation continuation mode	Ditto	0
	F579	Speed #10 operation continuation mode	Ditto	0
Patterned operation	F580	Speed #11 operation continuation mode	Ditto	0
	F581	Speed #12 operation continuation mode	Ditto	0
	F582	Speed #13 operation continuation mode	Ditto	0
	F583	Speed #14 operation continuation mode	Ditto	0
	F584	Speed #15 operation continuation mode	Ditto	0
	F585	Speed #1 operation time	1 to 8000 [sec./min.]	5
	F586	Speed #2 operation time	1 to 8000 [sec./min.]	5
	F587	Speed #3 operation time	1 to 8000 [sec./min.]	5
	F588	Speed #4 operation time	1 to 8000 [sec./min.]	5
	F589	Speed #5 operation time	1 to 8000 [sec./min.]	5
Patterned operation	F590	Speed #6 operation time	1 to 8000 [sec./min.]	5
	F591	Speed #7 operation time	1 to 8000 [sec./min.]	5
	F592	Speed #8 operation time	1 to 8000 [sec./min.]	5
	F593	Speed #9 operation time	1 to 8000 [sec./min.]	5
	F594	Speed #10 operation time	1 to 8000 [sec./min.]	5
	F595	Speed #11 operation time	1 to 8000 [sec./min.]	5
	F596	Speed #12 operation time	1 to 8000 [sec./min.]	5
	F597	Speed #13 operation time	1 to 8000 [sec./min.]	5
	F598	Speed #14 operation time	1 to 8000 [sec./min.]	5
	F599	Speed #15 operation time	1 to 8000 [sec./min.]	5
Protective functions	F600	Motor overload protection level 1	10~100 [%]	100
	F601	Stall prevention level 1	0~199[%], 200: Disabled	150
	F602	Selection of inverter trip holding	0: Cleared if power is turned off 1: Held even if power is turned off	0
	F603	Emergency stop mode selection	0: Coast stop 1: Deceleration stop 2: Emergency DC injection braking stop 3: Coast stop without FL output 4: Deceleration stop without FL output 5: Emergency DC injection braking without FL output	0
	F604	Emergency DC injection braking stop control time	0.0~10.0[sec.]	0.1
	F605	Output phase failure detection parameter	0: Not selected, 1: Selected	0
	F606	OL reduction starting frequency	0~30[Hz]	6.0
	F607	Motor 150% overload time limit	10~2400[sec.]	600
	F608	Timing of relay for suppressing rashed current	0.3~2.5[sec.]	0
	F609	Mode selection of relay for suppressing rashed current	0: Standard, 1: Gearing of ST	0
Protective functions	F610	Low current trip mode selection	0: Not selected 1: Selected	0
	F611	Low current (trip/alarm) detection current	0~100 [%]	0
	F612	Low current (trip/alarm) detection time	0~255[sec.]	0
	F613	Selection of output short-circuit pulse during start-up	0: Default setting, 1: Only one time when power is turned on or at first start after reset	0
	F614	Adjustment of output short-circuit pulse during start-up	1 to 100 [msec.]	50
	F615	Over-torque trip selection	0: Trip disabled 1: Trip enabled	0
	F616	Over-torque (trip/alarm) level during power operation	0~250 [%]	150
	F617	Over-torque (trip/alarm) level during regeneration	0~250 [%]	150
	F618	Over-torque detection time		

Protections

Trip display
Alarm display

List of trips

When a trip occurs, the panel LED immediately displays trip information. The cause of the trip is retained in memory even when the power is turned off.

Messages	Problems	Remedies
OC 1/OC 1P	Overcurrent during acceleration (DC section)	<ul style="list-style-type: none"> Extend the acceleration time ACC. Check the V/f parameter setting.
OC 2/OC 2P	Overcurrent during deceleration (DC section)	<ul style="list-style-type: none"> Extend the deceleration time DEC.
OC 3/OC 3P	Overcurrent during constant speed run (DC section)	<ul style="list-style-type: none"> Reduce the load fluctuation. Check the driven load.
Note) OC 1P OC 2P OC 3P	The above messages may also be displayed for reasons other than the above.	<ul style="list-style-type: none"> There may be a faulty element in the main circuit. Repair is required. Check the operation of the cooling fan. Check the cooling fan setting F620.
OCL	Overcurrent (load-side overcurrent during start-up)	<ul style="list-style-type: none"> Check the wiring and the insulation of the motor. Set the output short circuit detection F613 and F614.
OCRA 1	U-phase armature short circuit	<ul style="list-style-type: none"> There may be a faulty element (U-phase) in the main circuit. Repair is required.
OCRA 2	V-phase armature short circuit	<ul style="list-style-type: none"> There may be a faulty element (V-phase) in the main circuit. Repair is required.
OCRA 3	W-phase armature short circuit	<ul style="list-style-type: none"> There may be a faulty element (W-phase) in the main circuit. Repair is required.
EPH 1	Input phase failure	<ul style="list-style-type: none"> Check input-side circuits, including the input main circuit wiring, etc., for open phase.
*EPH0	Output phase failure	<ul style="list-style-type: none"> Check output-side circuits, including the output main circuit wiring, the motor, etc., for open phase. You can make a selection with the output open phase detection parameter F605.
OP 1	Overvoltage during acceleration	<ul style="list-style-type: none"> Check the input supply voltage.
OP 2	Overvoltage during deceleration	<ul style="list-style-type: none"> Extend the deceleration time DEC. Install a dynamic braking resistor. Set the dynamic braking operation F304. Set the overvoltage limit operation F305.
OP 3	Overvoltage during constant speed run	<ul style="list-style-type: none"> Check the input supply voltage.
OL 1/OL 2	Inverter overload trip motor overload trip	<ul style="list-style-type: none"> Replace the inverter with a higher-rated one because the load is too heavy. Extend the acceleration time ACC. Reduce the DC braking level F251 and shorten the DC braking time F252. The V/f characteristic or the torque boost is inadequate. Check the V/f parameter setting. Check the motor and the driven load to see whether the motor is bound. Adjust the F606 according to the low-speed overload withstanding capacity of the motor.
OLr	Dynamic braking resistor overload trip	<ul style="list-style-type: none"> Extend the deceleration time DEC. Use a braking resistor with a larger capacity (W) and adjust the PBR capacity parameter F309.
OH	Overheat	<ul style="list-style-type: none"> Reset and restart the inverter after the inverter has cooled down enough. Replace the fan if it does not run during operation. Repair is required. Secure a space enough for installation of the inverter.
E	Emergency stop	<ul style="list-style-type: none"> The inverter tripped because the emergency stop command was issued. Track down and remove the cause of the emergency stop, and then press the reset button.
EEP 1	EEPROM error	<ul style="list-style-type: none"> A data writing error occurred. Restart the inverter by turning on the power. If you fails to restore the inverter to a normal condition, Repair is required.
EEP 2	Initial read error	<ul style="list-style-type: none"> Data recorded in the inverter is defective. Repair is required.
EEP 3	Initial read error	<ul style="list-style-type: none"> An error occurred while data was being read from the main circuit EEPROM. Repair is required.
Err 2	Main unit RAM fault	<ul style="list-style-type: none"> The RAM in the microcomputer of the main unit is faulty. Repair is required.
Err 3	Main unit ROM fault	<ul style="list-style-type: none"> The ROM in the microcomputer of the main unit is faulty. Repair is required.
Err 4	CPU fault	<ul style="list-style-type: none"> The CPU in the microcomputer of the main unit is faulty. Repair is required.
Err 5	Communication interruption error	<ul style="list-style-type: none"> A communication error occurred. Check the communication devices, wiring, etc.
Err 6	Gate array fault	<ul style="list-style-type: none"> The gate array of the main unit is faulty. Repair is required.
Err 7	Output current detector error	<ul style="list-style-type: none"> The output current detector of the main unit is faulty. Repair is required.
Err 8	Optional unit fault	<ul style="list-style-type: none"> An optional device is faulty. Repair is required. For details, refer to the instruction manual for the device.
Err 9	Flash memory fault	<ul style="list-style-type: none"> The flash memory is faulty. Repair is required.
*UC	Trip during low-current run	<ul style="list-style-type: none"> The output current went down to the small current detection level. Check whether the small current detection level (F611) is set properly to match the system.
*UP 1	Undervoltage trip (main circuit)	<ul style="list-style-type: none"> The input voltage (main circuit) is too low for operation. There was a power failure which lasted for a time longer than the undervoltage detection time F628. Check the input voltage.
*UP 2	Undervoltage trip (control circuit)	<ul style="list-style-type: none"> The input voltage (control circuit) is too low for operation. There was a power failure which lasted for a time longer than the undervoltage detection time F628. Check the input voltage.
*Ot	Overtorque trip	<ul style="list-style-type: none"> During operation, the load torque went down to the over-torque detection level. Check whether the system is in a normal condition.
EF 1/EF 2	Grounding fault trip	<ul style="list-style-type: none"> A ground fault occurred in an output cable or the motor. Check the wiring and the motor for ground fault.
EFU	DC fuse broken	<ul style="list-style-type: none"> DC fuse of the main circuit is broken, repair is required.
Et	Auto-tuning error	<ul style="list-style-type: none"> Check the motor parameter settings F400 through F414. Initialize the motor constants and restart the system. (For details, refer to the instruction manual for the motor.)
EtYP	Inverter type error	<ul style="list-style-type: none"> When replacing the control circuit board (or main circuit board/drive circuit board), set EtYP 6 as the default value.
E-10	Sink/source switching error	<ul style="list-style-type: none"> The sink and the source are switched unexpectedly from one to another. Check the sequence before restarting the system.
E-11	Sequence error	<ul style="list-style-type: none"> The signal from a system is not inputted into input terminals. The input terminal function (I30 or I31) is not set up. For not using the system -supporting sequence F630 function it is set up except 0.0 at F630.
E-12	Encoder error	<ul style="list-style-type: none"> Wiring is broken, check the wiring. Motor is locked under the condition that the motor torque is limited by the torque limit function. Check the motor condition.
E-13	Speed error (over speed)	<ul style="list-style-type: none"> Encoder is broken, check the wiring.
E-14	Too much potential deviation	<ul style="list-style-type: none"> Potential deviation exceeded the F631 set value during position control. Check connection of encoder.
E-17	Key fault	<ul style="list-style-type: none"> The RUN key or the STOP key is pressed and held down for more than 5 seconds.

* A selection can be made between "parameter trip enabled" and "parameter trip disabled."

Alarm display

Messages	Problems	Remedies
OFF	ST-CC opened	<ul style="list-style-type: none"> The ST-CC circuit (standby signal) is opened. Close the circuit.
P0FF	Control circuit under voltage	<ul style="list-style-type: none"> The control voltage is too low between RO and SO. (Normally, the voltage in the main circuit goes down to an insufficient level when an 22kW and smaller inverter is used together with an optional unit.) Measure the control circuit supply voltage.
P0FF	Main circuit under voltage	<ul style="list-style-type: none"> The main circuit voltage is too low between R, S and T. Measure the main circuit supply voltage.
rtry	Display during retry	<ul style="list-style-type: none"> The inverter is in process of retry; it automatically restarts on completion of retry. After restart, the message rtry disappears, indicating that the inverter is in a normal condition. Take care when restarting the system; the motor abruptly starts rotating.
P-Err	Frequency point setting error alarm	<ul style="list-style-type: none"> The frequency setting signals point 1 and point 2 are set too close. Set the frequency setting signals point 1 and point 2 apart from each other.
CLr	Clear acceptance display	<ul style="list-style-type: none"> This message appears if the STOP key is pressed, while the trip is being displayed. Press the STOP key once again while CLr is being displayed to reset.
E0FF	Emergency stop acceptance display	<ul style="list-style-type: none"> This message appears if the STOP key on the control panel is pressed during terminal or communication operation. For an emergency stop, press the STOP key while E0FF is being displayed. To cancel the emergency stop, press any other key.
H/LD	Setting error alarm (The error detected and data are alternately displayed twice each.)	<ul style="list-style-type: none"> A setting error occurred during data reading or writing. Check the settings.
db dbon	DC braking in process	<ul style="list-style-type: none"> DC braking is in process. This message disappears within tens of seconds, indicating that the inverter has returned to its normal condition. Note) Motor shaft fixing operation is in process. This message disappears if the stop command is entered, indicating that the inverter has returned to its normal condition.
E1~E2	Digits over flow	<ul style="list-style-type: none"> The number of digits of an item to be displayed, e.g., frequency, exceeds that of the display panel (4 digits). Reduce the frequency magnification.
init	During initialization	<ul style="list-style-type: none"> All parameters are settled at default setting.
t	Communication error	<ul style="list-style-type: none"> At computer link, transmission error is occurred. Or at inverter communication, time over or trip of master inverter is occurred.
Ret	In auto-tuning	<ul style="list-style-type: none"> Under auto-tuning

Note) When the ON/OFF function is selected from the input terminal menu for DC braking (DB), if breaking the circuit formed by the terminal selected and the CC terminal causes the message **db** to disappear, then the inverter is in a normal condition.

[Messages displayed during operation]

Messages	Problems	Remedies
C	Overcurrent	Same as for OC
P	Overvoltage	Same as for OP
L	Overload	Same as for OL 1 and OL 2
H	Overheat	Same as for OH

If more than one problem arises at a time, the following messages blink. The blinking messages **C P L L H C P L ... C P L H** are displayed with their **C P L** and **H** arranged in this order from the left.

Resetting the inverter

If the inverter trips because of a fault or abnormal use, do not reset the inverter before removing the cause of the trip. Note that the inverter trips again if the cause of the trip has not yet been removed.

A tripped inverter can be reset by any of the following operations:

- Turn off the power (Make sure that the LED indicator goes out.)
If the inverter cannot be reset, check the inverter trip holding setting.
- External signal (control terminal board RES-CC circuit short-circuited -> opened)
- Control panel operation

★Note that the overload protective functions (**OL 1 OL 2 OLr**) cannot be reset during a virtual cooling time either by external signals or by control panel operation.
Approx. virtual cooling time ...
OL 1 : about 30 seconds after the occurrence of tripping
OL 2 : about 2 minute after the occurrence of tripping
OLr : about 20 seconds after the occurrence of tripping
 ★The overvoltage protective functions (**OP1 OP3**) cannot be reset until the DC voltage goes down below the overvoltage alarm level.
 ★When the overheat message (**OH**) is displayed, do not reset the inverter until it cools down enough. The inverter monitors the temperature in it.

Caution

The inverter can be restarted immediately by turning the power switch on after turning off temporarily. Note, however, that repeating this operation frequently may damage the inverter and the motor.

To reset the inverter from the control panel, follow the steps below.

- Press the [STOP] key and make sure that **CLr** is displayed.
- After removing the cause of tripping, press the [STOP] key again to reset the inverter.

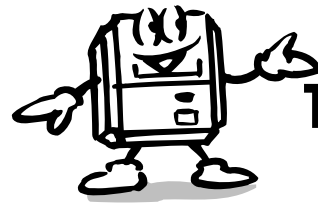

To users of our inverters

When wiring the inverter

Wiring precautions

Installing a molded-case circuit breaker (MCCB)

- (1) Install a molded-case circuit breaker (MCCB) on the inverter's power supply input to protect the wiring.
- (2) Avoid turning the MCCB breaker on and off frequently to turn on/off the motor.
- (3) To turn on/off the motor frequently, close/break the control terminals F (or R)-CC.

Installing a magnetic contactor [MC] [primary side]

- (1) To prevent an automatic restart after the power interruption or overload relay has tripped, or actuation of the protective circuit, install an electro-magnetic contact in the power supply.
- (2) Because the VF-A7 inverter has a built-in fault detection relay [FL], the primary end magnetic contactor (MC) can be configured to trip on activation of the inverter's protective functions by connecting the contact points of the FL to the operation circuit of the MC.
- (3) The inverter can be used without a magnetic contactor. In this case, use an MCCB (equipped with a voltage tripping device) for opening the primary circuit when the inverter protective circuit is activated.
- (4) Avoid turning the magnetic contactor on and off frequently to turn on/off the motor.
- (5) To turn off the motor frequently, close/break the control terminals F (or R)-CC.
- (6) Install a surge suppressor on the excitation coil of the magnetic contactor (MC).

Installing a magnetic contactor [MC] [secondary side]

- (1) As a rule, if a magnetic contactor is installed between the inverter and the motor, do not turn ON/OFF while running. (If the secondary-side contactor is turned ON/OFF while running, a large current may flow in the inverter, causing inverter damage and failure.)
- (2) A magnetic contactor may be installed to change the motor or change to the commercial power source when the inverter is stopped. Always use an interlock with the magnetic contactor in this situation so that the commercial power supply is not applied to the inverter's output terminals.

External signal

- (1) Use a relay rated for low currents. Mount a surge suppressor on the excitation coil of the relay.
- (2) When wiring the control circuit, use shielded wires or twisted pair cables.
- (3) Because all of the control terminals except FLA, FLB and FLC are connected to electronic circuits, insulate these terminals to prevent them from coming into contact with the main circuit.

Installing an overload relay

- (1) The VF-A7 inverter has a built-in overload protection function by means of a thermal relay. However, in the following cases, the thermal relay operation level must be adjusted or an overload relay matching the motor's characteristics must be installed between the inverter and the motor.
 - (a) When using a motor having a rated current value different from that of the equivalent.
 - (b) When driving several motors simultaneously.
- (2) When you want to use a constant-torque Toshiba VF motor together with the VF-A7 inverter, change the inverter's electronic thermal protection characteristics to match those of the VF motor.
- (3) In order to adequately protect a motor used for low-speed operation, we recommend the use of a motor equipped with an embedded thermal relay.

When changing the motor speed

Application to standard motors

Vibration

When a motor is operated with an industrial inverter, it experiences more vibrations than when it is operated by the commercial power supply. The vibration can be reduced to a negligibly level by fixing the motor and machine to the base firmly. If the base is weak, however, the vibration may increase at a light load due to resonance with the mechanical system.

Reduction gear, belt, chain

Note that the lubrication capability of a reducer or a converter used as the interface of the motor and the load machine may be affected at low speeds. When operating at a frequencies exceeding 60 Hz or higher, power transmission mechanisms such as reduction gear, belts and chains, may cause problems such as production of noise, a reduction in strength, or shortening of service life.

Frequency

Before setting the maximum frequency to 60 Hz or higher, confirm that this operating range is acceptable for the motor.

Application to special motors

Braking motor

When using a braking motor, if the braking circuit is directly connected to the inverter's output terminals, the brake cannot be released because of the lowered starting voltage. Therefore, when using a braking motor, connect the braking circuit to the inverter's power supply side, as shown in the figure below. Usually, braking motors produce larger noise in low speed ranges.

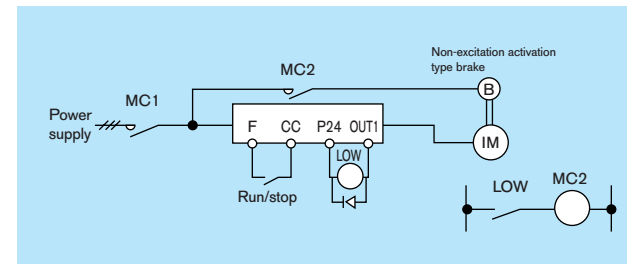

Gear motor

When using an industrial inverter to drive a gear motor, inquire of the motor manufacturer about its continuous operation range, since low-speed operation of a gear motor may cause insufficient lubrication.

Toshiba Gold Motor (High-efficiency power-saving motor)

Inverter-driven operation of Toshiba Gold Motors is the best solution for saving energy. This is because these motors have improved efficiency, power factor, and noise/vibration reduction characteristics when compared to standard motors.

Pole-changing motor

Pole-changing motors can be driven by the VF-A7 inverter. Before changing poles, however, be sure to let the motor come to a complete stop.

High-pole-count motors

Note that high-pole count motors (8 or more poles), which may be used for fans, etc., have higher rated current than 4-pole motors. The current ratings of multipole motors are relatively high. So, when selecting an inverter, you must pay special attention to its current rating so that the current rating of the motor is below that of the inverter.

Single-phase motor

Because single-phase motors are equipped with a centrifugal switch and capacitors for starting, they cannot be driven by an inverter. If only a single-phase, a 3-phase motor can be driven by using a single-phase input inverter to convert it into a 3-phase 200V output. (A special inverter and a 3-phase motor are required.)

Selection of wiring equipment

Voltage class	Applicable motor (kW)	Inverter	Molded-case circuit breaker (MCCB)		Magnetic contactor (MC)		Overload relay (THRY)		Earth leakage circuit breaker (ELCB)		Wire size Notes 3, 4 and 5				Screw size of Inverter terminal Note 5)		
			Rated current (A)	Toshiba Schneider Electric model	Rated current (A)	Toshiba Schneider Electric model	Adjusted current value (A) (Reference Value)	Toshiba Schneider Electric model	Rated current (A)	Toshiba Schneider Electric model	Main circuit (mm ²)	DC reactor (mm ²)	Dynamic braking resistor (mm ²)	Grounding (mm ²) Note 7)	Main circuit terminal Note 6)	Grounding terminal	
200V class	0.4	VFA7-2004PL	5	NJ30N	11	C11J	2.3	T13J	5	NJV50E	2.0	2.0	2.0	3.5	M4	M4	
	0.75	VFA7-2007PL	10	NJ30N	11	C11J	3.6	T13J	10	NJV50E	2.0	2.0					
	1.5	VFA7-2015PL	15	NJ30N	11	C11J	6.8	T13J	15	NJV50E	2.0	2.0					
	2.2	VFA7-2022PL	20	NJ30N	13	C13J	9.3	T13J	20	NJV50E	2.0	2.0					
	3.7	VFA7-2037PL	30	NJ30N	26	C25J	15	T20J	30	NJV50E	2.0	3.5	5.5	5.5	M5	M5	
	5.5	VFA7-2055PL	50	NJ50E	35	C35J	22	T35J	50	NJV50E	3.5	5.5					
	7.5	VFA7-2075PL	60	NJ100F	50	C50J	28	T35J	60	NJV60F	5.5	8	14	14	M6	M6	
	11	VFA7-2110P	100	NJ100F	65	C65J	44	T65J	100	NJV100F	14	14					
	15	VFA7-2150P	125	NJ225F	80	C80J	57	T65J	125	NJV225F	14	38	22	22	M8	M8	
	18.5	VFA7-2185P	125	NJ225F	93	C100J	70	T100J	125	NJV225F	22	38					
	22	VFA7-2220P	150	NJ225F	115	LC1D115J	85	T115J	150	NJV225F	38	38	38	38	M10	M8	
	30	VFA7-2300P	200	NJ225F	150	LC1D150J	108	T115J	200	NJV225F	60	60					
	37	VFA7-2370P1	225	NJ225F	185	LC1F185J	138	T150J	225	NJV225F	60	100	22	60	M12	M10	
	45	VFA7-2450P1	300	EH400	225	LC1F225J	162	T185J	300	LEH400	100	150					
400V class	55	VFA7-2550P1	350	EH400	330	LC1F330J	198	LR9F53J	350	LEH400	100	150	14X2	100	M10	M8	
	75	VFA7-2750P1	400	EH400			252	LR9F73J	400	LEH400	150	150					
	90	VFA7-2900P1	600	EH600	314	LR9F73J	600	LEH600	150	200	2.0	2.0	3.5	M4	M4		
	0.75	VFA7-4007PL	5	NJ30N	9	C11J	2.3	T13J	5	NJV50E						2.0	2.0
	1.5	VFA7-4015PL	10	NJ30N	9	C11J	3.6	T13J	10	NJV50E	2.0	2.0	2.0	2.0	5.5	M6	M5
	2.2	VFA7-4022PL	15	NJ30N	9	C11J	5.0	T13J	15	NJV50E	2.0	2.0					
	3.7	VFA7-4037PL	20	NJ30N	13	C13J	6.8	T13J	20	NJV50E	2.0	2.0	2.0	2.0	8	M6	M6
	5.5	VFA7-4055PL	30	NJ30N	17	C20J	11	T13J	30	NJV50E	2.0	2.0					
	7.5	VFA7-4075PL	30	NJ30N	25	C25J	15	T20J	30	NJV50E	2.0	3.5	5.5	5.5	M8	M6	
	11	VFA7-4110PL	50	NJ50E	32	C35J	22	T35J	50	NJV50E	3.5	5.5					
	15	VFA7-4150PL	60	NJ100F	48	C50J	28	T35J	60	NJV100F	5.5	8.0	14	14	M8	M8	
	18.5	VFA7-4185P	75	NJ100F	48	C50J	35	T65J	75	NJV100F	8.0	14					
	22	VFA7-4220P	100	NJ100F	65	C65J	44	T65J	100	NJV100F	14	14	22	22	M10	M10	
	30	VFA7-4300P	125	NJ225F	80	C80J	57	T65J	125	NJV225F	14	22					
37	VFA7-4370P1	125	NJ225F	100	C100J	65	T100J	125	NJV225F	22	38	38	38	M12	M12		
45	VFA7-4450P1	150	NJ225F	115	LC1D115J	85	T115J	150	NJV225F	38	60						
55	VFA7-4550P1	175		150	LC1D150J	100	175	LR9F73J	175	NJV225F	38	60	14	60	M10	M10	
75	VFA7-4750P1	250	EH400	185	LC1F185J	138	T150J	250	LEH400	60	100						
90	VFA7-4110KP1	300	EH400	225	LC1F225J	157	LR9F53J	300	LEH400	100	100	22	100	M12	M12		
/110		350		198	350												
132	VFA7-4132KP1	400	EH400	265	LC1F265J	252	LR9F73J	400	LEH400	150	150	100	150X2	22X2	150	M12	
160	VFA7-4160KP1	500	EH600	330	LC1F330J	268	LR9F73J	500	LEH600	200	200X2						
220	VFA7-4220KP1	600	EH600	400	LC1F400J	396	LR9F73J	600	LEH600	200	150X2	22X2	60X2	150	M12	M12	
280	VFA7-4280KP1	800	EH800	630	LC1F630J	460	LR9F73J	800	EH800 +LRE +ZCT	150X2	200X2						

Note 1). Attach a surge killer to the exciting coil of every magnetic contactor and relay. Selection of surge killers for Toshiba Schneider Electric magnetic contactors 200V class: surge absorbing unit (optional) for the Toshiba Schneider Electric C11J to C65J or SS-2 surge killer for the Toshiba Schneider Electric C50J and C65J. 400V class: The voltages of the operation and control circuits should be reduced below 200V with a step-down transformer.

Note 2). When using a magnetic contactor MC with auxiliary 2a contacts for the control circuit, connect the 2a contacts in parallel to improve their reliability.

Note 3). The above table provides a listing of wires of the type HIV 600V and of the sizes R, S and T for the input-side of the main circuit, and U, V and W for the output-side. The above type and sizes of wires are applicable only when the wiring distance between the inverter and the motor is not more than 30m.

Note 4). Use a 0.75mm² or larger shielded wire for the control circuit.

Note 5). Control terminal : μ3 size.

Note 6). R, S, T, U, V and W terminals. M4 for the control power input terminals R0, R41, R46, S0, R20 and S20.

Note 7). For grounding, use a cable with a size equal to or larger than the above.

When studying how to use our inverters

Notes

Leakage current

The VF-A7 series of inverters uses high-speed switching devices for PWM control. When a relatively long cable is used for power supply to an inverter, current may leak from the cable or the motor to the ground because of its capacitance, adversely affecting the peripheral equipment. The intensity of such a leakage current depends on the PWM carrier frequency, the lengths of the input and output cables, etc., of the inverter. To prevent current leakage, it is recommended to take the following measures.

[Effects of leakage current]

Leakage current which increases when an inverter is used may pass through the following routes:

- Route (1) ... Leakage due to the capacitance between the ground and the noise filter
- Route (2) ... Leakage due to the capacitance between the ground and the inverter
- Route (3) ... Leakage due to the capacitance between ground and the cable connecting the inverter and the motor
- Route (4) ... Leakage due to the capacitance of the cable connecting the motor and an inverter in another power distribution line
- Route (5) ... Leakage through the grounding line common to motors
- Route (6) ... Leakage to another line because of the capacitance of the ground

Leakage current which passes through the above routes may cause the following trouble.

- Malfunction of a leakage circuit breaker in the same or another power distribution line
- Malfunction of a ground-relay installed in the same or another power distribution line
- Noise produced at the output of an electronic device in another power distribution line
- Activation of an external thermal relay installed between the inverter and the motor, at a current below the rated current

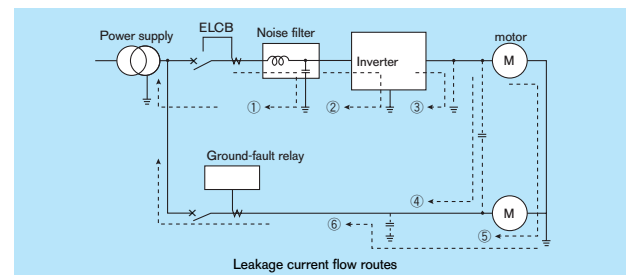

[Measures against effects of leakage current]

The measures against the effects of leakage current are as follows:

- 1) Measures to prevent the malfunction of leakage circuit breakers
 - (1) Decrease the PWM carrier frequency of the inverter. In the case of the VF-A7, the frequency can be decreased up to 0.5kHz. (*)
 - (2) Install leakage circuit breakers (ELCB) with a high-frequency protective function (e.g., Toshiba Mighty series of breakers) in both the same and the other power distribution lines. This makes it possible to operate the VF-A7 with its PWM carrier frequency set high.
- 2) Measures against malfunction of ground-fault relay
 - (1) Decrease the PWM carrier frequency of the inverter. In the case of the VF-A7, the frequency can be decreased up to 0.5kHz. (*)
 - (2) Install ground-fault relays with a high-frequency protective function (e.g., Toshiba CCR12 type of relays) in both the same and other lines. This makes it possible to operate the VF-A7 with its PWM carrier frequency set high.
- 3) Measures against noise produced by other electric and electronic systems
 - (1) Separate the grounding line of the inverter from that of the affected electric and electronic systems.
 - (2) Decrease the PWM carrier frequency of the inverter. In the case of the VF-A7, the frequency can be decreased up to 0.5kHz. (*)
- 4) Measures against malfunction of external thermal relays
 - (1) Remove the external thermal relay and use the electronic thermal function of the inverter instead of it. (Unapplicable to cases where a single inverter is used to drive more than one motor. Refer to the instruction manual for measures to be taken when thermal relays cannot be removed.)
 - (2) Decrease the PWM carrier frequency of the inverter. In the case of the VF-A7, the frequency can be decreased up to 0.5kHz.

(Note) Reducing the carrier frequency causes an increase in the magnetic noise caused by the motor.

5) Measures by means of wiring and grounding

- (1) Use a grounding wire as large as possible.
 - (2) Separate the inverter's grounding wire from that of other systems or install the grounding wire of each system separately to the grounding point.
 - (3) Ground (shield) the main circuit wires with metallic conduits.
- (*) The PWM carrier frequency should not be decreased below 2.2kHz in the vector control mode.

Ground fault

Before beginning operation, thoroughly check the wiring between the motor and the inverter for incorrect wiring or short circuits. Do not ground the neutral point of any star-connected motor.

Radio interference

[Noise produced by inverters]

Since the VF-A7 series of inverters performs PWM control, it produces noise and sometimes affects nearby instrumental devices, electrical and electronic systems, etc. The effects of noise greatly vary with the noise resistance of each individual device, its wiring condition, the distance between it and the inverter, etc.

[Measures against noises]

According to the route through which noise is transmitted, the noises produced by an inverter are classified into transmission noise, induction noise and radiation noise.

[Examples of protective measures]

- Separate the power line from other lines, such as weak-current lines and signal lines, and install them apart from each other.
- Install a noise filter in each inverter. It is effective for noise prevention to install noise filters in other devices and systems, as well.
- Shield cables and wires with grounded metallic conduits, and cover electronic systems with grounded metallic cases.
- Separate the power distribution line of the inverter from that of other devices and systems.
- Install the input and output cables of the inverter apart from each other.
- Use shielded twisted pair wires for wiring of the weak-current and signal circuits, and always ground one of each pair of wires.
- Ground the inverter with grounding wires as large and short as possible, separately from other devices and systems.

The 200V 0.4-7.5kW and 400V 0.75-15kW models have built-in noise filters which significantly reduce noise.

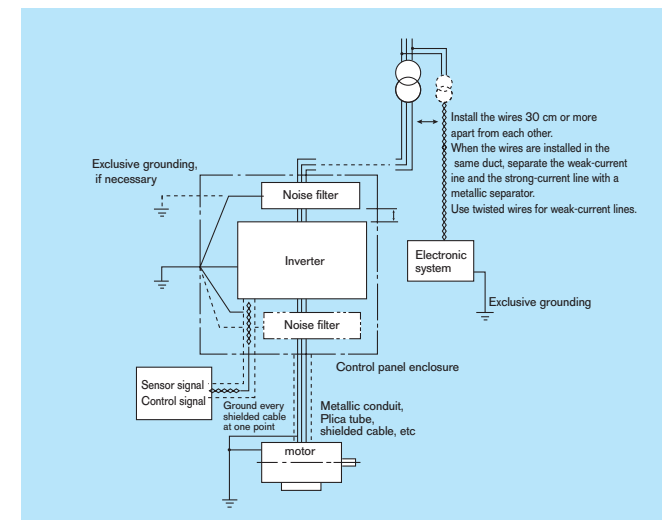

Power factor improvement capacitors

Do not install a power factor improvement capacitors on the input or output side of the inverter.

Installing a power factor improvement capacitor on the input or output side causes current containing harmonic components to flow into the capacitor, adversely affecting the capacitor itself or causing the inverter to trip. To improve the power factor, install an input AC reactor or a DC reactor (optional) on the primary side of the inverter.

Installation of input AC reactors

These devices are used to improve the input power factor and suppress high harmonic currents and surges. Install an input AC reactor when using a VF-A7 inverter under the following conditions:

- (1) When the power source capacity is 500kVA or more, and when it is 10 times or more greater than the inverter capacity.
- (2) When the inverter is connected the same power distribution system as a thyristor-committed control equipment.
- (3) When the inverter is connected to the same power distribution system as that of distorted wave-producing systems, such as arc furnaces and large-capacity inverters.

Standard replacement intervals of main parts

The table below lists standard component replacement intervals under normal operating conditions (i.e., average year round ambient temperature of 30°C, load ratio of 80% or less, average operation time of 12 hours/day). The replacement intervals do not indicate the service life of each component, but the number of years beyond which the failure rate of a component used without being replaced increases sharply because of deterioration and wear.

Component name	Standard replacement intervals	Replacement method, etc.
Cooling fan	2 to 3 years	Replaced with a new one
Smoothing capacitor	5 years	Replaced with a new one (upon examination)
Contactors, relay	—	Decided upon examination
Fuse	10 years	Replaced with a new one
Aluminum capacitors on the	5 years	Replaced with a new circuit board (upon examination)

Extract from "Periodic Inspection of General-purpose Inverters" published by the Japan Electrical Manufacturers' Association
Note: The service life of each component greatly varies with its usage environment.

Selecting the capacity (model) of the inverter

Selection

Capacity

Refer to the applicable motor capacities listed in the standard specifications. When driving a high-pole motor, special motor, or multiple motors in parallel, select such an inverter that the sum of the motor rated current multiplied by 1.05 to 1.1 is less than the inverter's rated output current value.

Acceleration/deceleration times

The actual acceleration and deceleration times of a motor driven by an inverter are determined by the torque and GD² of the load, and can be calculated by the following equations.

The acceleration and deceleration times of an inverter can be set individually. In any case, however, they should be set longer than their respective values determined by the following equations.

	SI unit system	Conventional unit system (for reference)
Acceleration time	$t_a = \frac{(J_m + J_l) \times \Delta N}{9.56 \times (T_m - T_l)} \text{ (sec.)}$	$t_a = \frac{(GD^2_m + D^2_l) \times \Delta N}{375 \times (T_m - T_l)} \text{ (sec.)}$
Deceleration time	$t_a = \frac{(J_m + J_l) \times \Delta N}{9.56 \times (T_m + T_l)} \text{ (sec.)}$	$t_a = \frac{(GD^2_m + D^2_l) \times \Delta N}{375 \times (T_m + T_l)} \text{ (sec.)}$
Conditions	J_m : Moment of inertia of motor (kg·m ²) J_l : Moment of inertia of load (kg·m ²) (converted into value on motor shaft) ΔN : Difference in rotating speed between before and after acc. or dec. (min. ⁻¹) T_l : Load torque (N·m) T_m : Motor rated torque x 1.2-1.3 (N·m) ... V/f control ... Motor rated torque x 1.5 (N·m) ... Vector operation control T_b : Motor rated torque x 0.2 (N·m) (When a braking resistor or a braking resistor unit is used.) (Motor rated torque x 0.8-1.0 (N·m))	GD^2_m : Motor GD ² (kg·m ²) (converted into value on motor shaft) D^2_l : Load GD ² (kg·m ²) ΔN : Difference in rotating speed between before and after acc. and dec. (rpm) T_l : Load torque (kg·m) T_m : Motor rated torque x 1.2-1.3 (N·m) ... V/f control ... Motor rated torque x 1.5 (kg·m) ... Vector operation control T_b : Motor rated torque x 0.2 (kg·m) (When a braking resistor or a braking resistor unit is used.) (Motor rated torque x 0.8-1.0 (kg·m))

Allowable torque characteristics

When a standard motor is combined with an inverter to perform variable speed operation, the motor temperature rises slightly higher than it normally does during commercial power supply operation. This is because the inverter output voltage has a sinusoidal (approximate) PWM waveform. In addition, the cooling becomes less effective at low speed, so the torque must be reduced according to the frequency. When constant-torque operation must be performed at low speeds, use a Toshiba VF motor designed specifically for use with inverters.

Starting characteristics

When a motor is driven by an inverter, its operation is restricted by the inverter's overload current rating, so the starting characteristic is different from those obtained from commercial power supply operation. Although the starting torque is smaller with an inverter than with the commercial power supply, a high starting torque can be produced at low speeds by adjusting the V/f pattern torque boost amount or by employing vector control. (200% in sensorless control mode, though this rate varies with the motor characteristics.) When a larger starting torque is necessary, select an inverter with a larger capacity and examine the possibility of increasing the motor capacity.

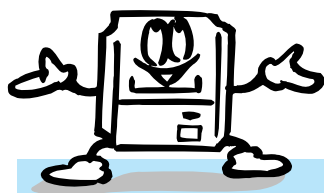

Application and functions of options

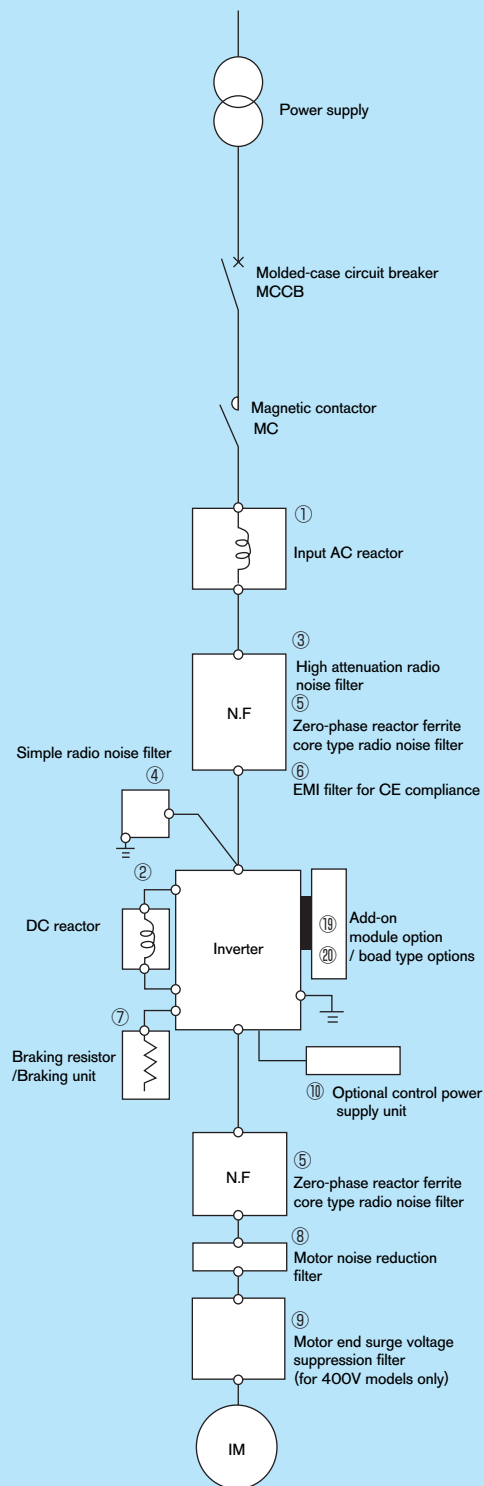

Protection options.

name	Function, purpose
Fin attached externally option	Calory of the inverter reduction and dustproof effective.

No.	Name	Function, purpose
①	Input AC reactor	Improves the input power factor, reduces higher harmonics, and suppress external surge on the inverter power supply. Install when the power supply capacity is 500kVA or more and exceeds 10 times the inverter capacity, or when distorted wave-producing systems, such as thyristors and large inverters, are connected to the same power distribution line. To ensure the reactance is effective, contact us because it varies with the impedance.
②	DC reactor	DC reactors improve the power factor more efficiently than input AC reactors. When an inverter is used for a system for which high reliability is required, you should preferably use a DC reactor together with an input AC reactor, because input AC reactors are effective for suppression of external surge.
③	High-attenuation filter (LC filter)N.F type, manufactured by Soshin Denki Co., Ltd.	<ul style="list-style-type: none"> Effective in preventing radio interference noise to audio equipment installed near the inverter. Installed on the input side of the inverter. Attenuation characteristic is available in a wide range from AM band to 10 MHz. Use this type when equipment vulnerable to noise is installed in the vicinity of the inverter.
④	Simple filter (capacitive filter) Capacitor type, manufactured by Malcon Electronics Co., Ltd.	<ul style="list-style-type: none"> Effective in preventing radio interference noise to audio equipment installed near the inverter. Installed on the input side of the inverter. Attenuation characteristic is available only in a specific frequency band. Effective in suppressing noise in a specific AM Radio station(e.g., weak radio waves in mountainous regions). Increases leakage current because this is a capacitor-based filter. When the power supply is equipped with an ELCB, avoid using too many filters of this type.
⑤	Zero-phase reactor (inductive filter) Ferrite core type, manufactured by Soshin Denki Co., Ltd.	<ul style="list-style-type: none"> Effective for preventing radio interference noise to audio equipment installed near the inverter. Effective for noise reduction on both the input and output sides of an inverter. Attenuation characteristic is available in several decibels in a frequency range of AM radio band to 10MHz.
⑥	EMI filter for CE compliance by SCHFFNER	Can conform to CE marking, by using this filter and wiring properly.
⑦	Braking resistor	Used to reduce the deceleration time, for example, when frequent rapid deceleration or stop is required or the load has a large moment of inertia. A resistor designed to consume energy during dynamic braking.
⑧	Motor noise reduction filter (for large-capacity models only)	Can be used to suppress the magnetic noise from motor. If the reactor is connected, the magnetic noise from the motor can be reduced by several dB to 10dB (A). (Note that the reactor itself produces a low level of magnetic noise.)
⑨	Motor end surge voltage suppression filter (for 400V models only)	When a voltage PWM control inverter with ultra-high-speed switching devices (e.g., IGBT) is used to drive a general-purpose motor with a rating of 400V or so, a surge voltage depending on the cable length, cable installation method, cable constant, etc., may damage the insulation of motor coils. In such a situation, it is necessary to use a motor with insulation-reinforced coils or install an AC reactor, a surge suppression filter, etc., on the output side of the inverter in order to reduce surge voltage.
⑩	Optional control power supply unit	For 22kW models and smaller in which control power is supplied by the main circuit power supply unit, there is no need to supply control power through terminal R0 or S0. For 22kW models and smaller, use an optional control power supply unit if there is a need to supply control power separately from main circuit power. (30kW and larger models come standard with a control power supply unit.) Installing a control power supply unit (for 22kW models and smaller) To install a control power supply unit, remove the jumper connector (CN21) inside the inverter and then connect an optional connector. Install the control power supply unit near the inverter main unit.
⑪	Parameter writer	Unit for reading, copying and writing parameters in batch processing (PWU001Z-0)
⑫	Extended panel	Extended panel with an LED display, a RUN/STOP key, a UP/DOWN key, a MONITOR key and an ENTER key
⑬	RS232C converter unit	This unit is used for data communication via a personal computer. It also allows you to change parameters and save and write data by remote control via an interface cable. This communication unit, which supports RS232C standard, can be connected to two inverters at the same time. ■Monitoring function ■Parameter setting function ■Command function ■Additional functions
⑭	RS485 converter unit (When connected to 2 inverters)	This unit is capable of operating a maximum of 64 inverters via a personal computer. ●Computer link ... By connecting this unit to a host processor or FA computer, you can organize a network for data communication between inverters. ●Inverter-to-inverter communications ... Using this unit, you can organize a network for transmission of frequency data, which is required for proportional operation of multiple inverters.
⑮	Communication cable	Cables for connection of parameter writers, extension operation panels, RS232C communication units, and RS485 communication units. Model: CAB0011 (1 m), CAB0013 (3 m), CAB0015 (5 m)
⑯	Remote control panel	Equipped with a frequency meter, a frequency setter, and RUN/STOP switches (forward/reverse). (Model: CBVR-7B1)
⑰	Application control unit	The AP series of control units are available for the VF-P7 to allow it to carry out various types of control.
⑱	Harmonic suppression converter/Power regeneration converter	<ul style="list-style-type: none"> Designed to suppress harmonics and improve the power factor. Units suitable for loads which frequently undergo rapid deceleration or loads which require minus torque. Contact your Toshiba dealer for applicable models and details.

Add-on module options

No.	name	Function, purpose
①	Sensor vector control unit (multiple functions)	Allows still more accurate control if used in combination with a sensor-equipped motor. (Speed control, torque control, and positioning control)
②	Extended terminal	Useful in adding special functions to the inverter
③	S20 communication	Designed for communication with a programmable controller over a field network. This unit allows high-speed communication (2 Mbps) via an optical fiber cable.
④	F10M communication	Designed for communication with a programmable controller over a field network. Bus-type data transmission unit which uses shielded twisted pair cables for the data transmission line and is designed specifically for small industry-intended Toshiba inverters for motor drives.
⑤	RS485 converter unit (When connected to 8 inverters.)	This unit is capable of operating a maximum of 256 inverters via PLC or personal computer. (Depend on function of the inverter model.)

Board type options.

No.	name	Function, purpose
①	Sensor vector control unit (complementary output/time driver output)	Allows still more accurate control if used in combination with a sensor-equipped motor. (speed control and torque control)



Add-on module/board type options

The following add-on module options and board type options are available for the VF-A7 series of inverters.

Table of add-on module/board type options

Table of add-on module options (with Inverter produced since 2000.)

*Use ⑧ attachment for mounting add-on cassette options.

Option	Function/purpose	Type	Remarks (Note 1)	
①PG feedback option #1 (Multi-function)	This unit is needed for the PG feedback control. Control modes are speed, torque and positioning.	VEC001Z	Group A	
②Extended terminal board option	Required for using the extended terminal function	ETB001Z		
Communication function	③TOSLINE-S20 option	Required for using TOSLINE-S20	Group B	
	④TOSLINE-F10M option	Required for using TOSLINE-F10M		
	⑤Device Net option	Required for using Device Net		
	⑥Profibus option	Required or using Profibus		
⑦LonWorks option	Required or using LonWorks	Planned		
⑧Add-on cassette option attachment	Attachment for mounting add-on cassette options	For 75(132)kW and smaller models For 90(160)kW and larger models	SBP001Z SBP002Z	(Note 2)

Notes)

1. The options in group A can be used together. The options in groups A and B can also be used together, but the options in group B cannot be used together with any other option in the same group.
2. () means 400V class.

Table of board type options

Options	Function/purpose	Type	Remarks
PG feed back option#2 (Complimentary output)	This unit is needed for the PG feedback control. Control modes are speed and torque control.	VEC002Z	Cannot use add-on cassette options together
PG feed back option#3 (Line-driver output)		VEC003Z	

Functions of add-on module/board type options

① PG feedback options

Function	Type	VEC001Z	VEC002Z	VEC003Z
Characteristics(Speed/torque)		Speed control:150% torque at 0 speed, control range 1: 1000, precision ±0.02% Torque control:precision ±10%, control range -100% to +100%		
Speed control	Accuracy	Digital:±0.01% Analogue:±0.1%	Digital:±0.01% Analogue:±0.1%	Digital:±0.01% Analogue:±0.1%
	Reference	0 to ±10V, 0 to +10V, 4 to 20mA	0 to ±10V, 0 to +10V, 4 to 20mA	0 to ±10V, 0 to +10V, 4 to 20mA
Torque control	Reference	0 to ±10V, 0 to +10V, 4 to 20mA		
	Input pulse	Forward/reverse pulse		
Positioning*	Max. pulse freq.	160kpps	Not available	Not available
	Electrical gear	100 to 4000 ppr		
PG feed-back method	Line driver(30m)	Complimentary(100m)	Line driver(30m)	
	Complimentary(100m)	Open-collector(10m)		
	Open-collector(10m)			
PG power source		5/6/12/15V	12V(fixed)	5V(fixed)
Voltage compensation of PG output		Available	Not available	Not available
Breaking detection of sensor cable (during operation)		Available	Available	Available
Breaking detection of sensor cable (during stand-by)		Available	Not available	Not available
±10V analogue reference		Available	Not available	Not available
Programmable output terminal		2 terminal(Sink/source)	Not available	Not available
Alarm signal output		4 terminal(Sink/source)	Not available	Not available

② Extended terminal add-on module options

Function	Description	
Contact input	16-bit binary (12-bit binary)	<ul style="list-style-type: none"> Sink logic ON: DC 11V and 2.5 mA or more (Max. DC30V) OFF: DC5V or less or 1.4mA or less
	4-digit BCD (3-digits BCD code)	<ul style="list-style-type: none"> Source logic ON: DC5V or less (5mA type) OFF: DC 11V or more or 0.5mA or less
	Multifunction programmable contact input (higher order 8 bits)	
Multifunction programmable analog output (current/voltage switchable)	<ul style="list-style-type: none"> Current: DC4-20mA output (source output) Connectable largest resistor: 750Ω Voltage: DC+/-10V output 	
Multifunction programmable relay contact output	<ul style="list-style-type: none"> 1a-/1b-contact output (2 circuits) Contact ratings: 250Vac-2A (cos φ = 1) 250Vac-1A (cos φ = 0.4) 30Vdc-1A 	

■ Installation of Add-on module options (200V:75kW or less) (400V:132kW or less)
Connect Add-on cassette option to the right side of VF-A7 via an attachment (SBP001)

1 cassette : 48.5mm and more
2 cassettes : 73.5 //
3 cassettes : 98.5 //

■ Installation of Add-on module options (200V:90kW or more) (400V:160kW or more)
Connect Add-on cassette option to the right side of the operating panel via an attachment (SBP002Z)
L=50.0mm and more

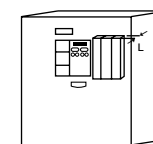
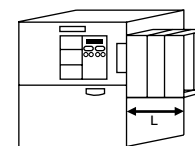

Stand-alone options

Voltage class	Applicable motor (kW)	Inverter model	Input AC reactor model	DC reactor model	Radio noise reduction filter			Braking resistor/braking resistor unit model (Note 2) (Note 4)	Filter for suppressing surge voltage on motor-side model	Motor noise reduction reactor
					High attenuation type	Simple type	Core type (Note 1)			
200V class	0.4	VFA7-2004PL	PFL-2005S	DCL-2007	Each type of inverter has a built-in noise filter.	-	-	-	-	-
	0.75	VFA7-2007PL								
	1.5	VFA7-2015PL								
	2.2	VFA7-2022PL								
	3.7	VFA7-2037PL								
	5.5	VFA7-2055PL								
	7.5	VFA7-2075PL	PFL-2050S	DCL-2110	NF3050A-MJ	RC9129	PBR3-2055	-	-	
	11	VFA7-2110P								
	15	VFA7-2150P	PFL-2100S	DCL-2220	NF3080A-MJ	RCL-M2	PBR3-2150	-	-	
	18.5	VFA7-2185P								
	22	VFA7-2220P	PFL-2150S	DCL-2370	NF3100A-MJ	RC9129X4-S (Note 3)	PBR3-2220	-	-	
	30	VFA7-2300P								
	37	VFA7-2370P1	PFL-2200S	DCL-2450	NF3150A-MJ	RC9129X4-S (Note 3)	PB3-2300	-	-	
	45	VFA7-2450P1								
	55	VFA7-2550P1	PFL-2300S	DCL-2550	NF3200A-MJ	RC9129X4-S (Note 3)	PB3-2550	-	-	
	75	VFA7-2750P1								
90	VFA7-2900P1	PFL-2600S	DCL-2900	NF3250A-MJ x 2P	RC9129X4-S (Note 3)	DPG600W-B1 [DGP600W-C1]	-	-		
400V class	0.75	VFA7-4007PL	PFL-4012S	DCL-2007	Each type of inverter has a built-in noise filter.	-	-	MSF-4015Z	-	
	1.5	VFA7-4015PL								
	2.2	VFA7-4022PL								
	3.7	VFA7-4037PL	DCL-2022							
	5.5	VFA7-4055PL								
	7.5	VFA7-4075PL	PFL-4025S	DCL-4110						PBR3-4055
	11	VFA7-4110PL								
	15	VFA7-4150PL	PFL-4050S	DCL-4220	NF3040C-MJ	RCL-M4	PBR3-4075	-	-	
	18.5	VFA7-4185P								
	22	VFA7-4220P	PFL-4100S	DCL-4450	NF3050C-MJ	RC9129X4-S (Note 3)	PBR3-4110	-	-	
	30	VFA7-4300P								
	37	VFA7-4370P1	PFL-4150S	DCL-4750	NF3080C-MJ	RC9129X4-S (Note 3)	PBR3-4150	-	-	
	45	VFA7-4450P1								
	55	VFA7-4550P1	PFL-4300S	DCL-4110K	NF3100C-MJ	RC9129X4-S (Note 3)	PBR3-4220	-	-	
	75	VFA7-4750P1								
	90/110	VFA7-4110KP1	PFL-4400S	DCL-4160K	NF3250C-MJ	RC9129X4-S (Note 3)	PBR3-4300	-	-	
	132	VFA7-4132KP1								
	160	VFA7-4160KP1	PFL-4600S	DCL-4220K	NF3200C-MJ x 2P	RC9129X4-S (Note 3)	PB3-4550	-	-	
220	VFA7-4220KP1									
280	VFA7-4280KP1	PFL-4800S	DCL-4280K	NF3250C-MJ x 2P	RC9129X4-S (Note 3)	DPG600W-B2 [DGP600W-C2]	-	-		
				NF3250C-MJ x 3P		DPG600W-B3 [DGP600W-C3]				
						DPG600W-B4 [DGP600W-C4]				

Notes)

- This filter needs to be wound around the input side of the power line (number of turns: 4 turns or more). This filter can be used for the output side of the power line, as well. For filters with 22mm² and larger wires, at least four filters should be installed in series. A round type (model: RC5078) is also available.
- Each model between brackets is provided with a drip cover.
- This type of filters cannot be used for certain sizes of cables.
- As options, dynamicbraking circuit is needed.200V-75kW or more, 400V-110kW or more.

Name	Type
Option Control power supply unit	CPS0011(200V/400V)
Parameter writer	PWU001Z
Extention panel	RKPO01Z
RS232C communication control unit	RS2001Z Computer cable type:CAB0025
RS485 communication control unit	RS4001Z, RS4002Z
Communication cable	CAB0011(1m), CAB0013(3m), CAB0015(5m)

Useful information when ordering

Machine application	Type Manufacturer Application	Fan, blower, pump, other()	
Motor specifications	Rated capacity	kW(HP)	No. of poles
	Rated voltage	V	Rated frequency Hz
	Rated current	A	Time rating
	Model	Manufacturer	
	Existing or new		
Inverter specifications	Rated capacity	kVA	Power supply Phase V Hz
	Output voltage	V	Output frequency Hz
	Frequency range	Hz to	Hz
	Motor speed range	min ⁻¹ to	min ⁻¹
	Options		
Driving conditions	Starting frequency	Hz	Starting torque
	Acceleration, deceleration times	Specified	
	Load GD ²	No•Yes (s.)	
	Regenerative brake	Required (Injection brake unit used)•Not required	
Other special items			

EMI noise filter for CE marking

Can conform to CE marking, by using these filters and wiring properly.

Inverter model	Filter model
VFA7-2110P	FN258-75/34
VFA7-2150P	FN258-100/35
VFA7-2185P	FN258-100/35
VFA7-2220P	FN258-100/35
VFA7-2300P	FN258-130/35
VFA7-2370P1	FN258-180/07 FN3258-180/40
VFA7-2450P1	FN258-130/35X2P FN258-250/07 FN3359-250/28
VFA7-2550P1	FN258-130/35X2P FN258-250/07 FN3359-250/28
VFA7-2750P1	FN359-300/99 FN3359-320/99
VFA7-2900P1	FN359-400/99 FN3359-400/99

Inverter model	Filter model
VFA7-4185P	FN258-42/07
VFA7-4220P	FN258-55/07
VFA7-4300P	FN258-75/34
VFA7-4370P1	FN3258-75/52 FS5992-72/52
VFA7-4450P1	FN258-100/35 FN3258-100/35
VFA7-4550P1	FN3258-130/35 FS5992-130/35
VFA7-4750P1	FN258-180/07 FN3258-180/40
VFA7-4110KP1	FN359(H)-250/99 FN3359(HV)-250/28
VFA7-4132KP1	FN359(H)-300/99 FN3359(HV)-320/99
VFA7-4160KP1	FN359(H)-400/99 FN3359(HV)-400/99
VFA7-4220KP1	FN359(H)-500/99 FN3359(HV)-500/99
VFA7-4280KP1	FN359(H)-600/99 FN3359(HV)-600/99

Note) Input Voltage
 FN258, FN3258 480V or less
 FN359 400V or less, FN359H 520V or less
 FN3359 500V or less, FN3359HV 690V or less

These filters are not needed for 200V class. 0.4~7.5kW, 400V class 0.75~15kW. Because these units have EMI filter inside.

These filters are made by SCHAFFNER