

# TOSHIBA

# VF-S9

## Compact Inverter TOSVERT

1-phase 200V 0.2kW to 2.2kW  
3-phase 200V 0.2kW to 15kW  
3-phase 400V 0.75kW to 15kW

**To users of our inverters:** Our inverters are designed to control the speeds of three-phase induction motors for general industry.

### ⚠ Precautions

- \* Read the instruction manual before installing or operating the inverter unit and store it in a safe place for reference.
- \* When using our inverters for equipment such as nuclear power control equipment, aviation and space flight control equipment, traffic equipment, and safety equipment, and there is a risk that any failure or malfunction of the inverter could directly endanger human life or cause injury, please contact our headquarters, branch, or office printed on the front and back covers of this catalogue. Such applications must be studied carefully.
- \* When using our inverters for critical equipment, even though the inverters are manufactured under strict quality control always fit your equipment with safety devices to prevent serious accident or loss should the inverter fail (such as failure to issue an inverter trouble signal).
- \* Do not use our inverters for any load other than three-phase induction motors.
- \* None of Toshiba, its subsidiaries, affiliates or agents, shall be liable for any physical damages, including, without limitation, malfunction, anomaly, breakdown or any other problem that may occur to any apparatus in which the Toshiba inverter is incorporated or to any equipment that is used in combination with the Toshiba inverter. Nor shall Toshiba, its subsidiaries, affiliates or agents be liable for any compensatory damages resulting from such utilization, including compensation for special, indirect, incidental, consequential, punitive or exemplary damages, or for loss of profit, income or data, even if the user has been advised or apprised of the likelihood of the occurrence of such loss or damages.

For further information, please contact your nearest Toshiba Representative or International Operations-Producer Goods.  
The information in this brochure is subject to change without notice.



# TOSHIBA

**TOSHIBA CORPORATION**

Industrial Equipment Department  
1-1, Shibaura 1-chome, Minato-ku,  
Tokyo 105-8001, Japan  
Tel: (03)3457-4911 Fax: (03)5444-9268

Environment-friendly, Handy Inverter — All Models, EMI Noise Filter Inside

# Introducing the New-Generation Compact Inverter! Easy to Use, Powerful Performance, and Wide Applications



**Major World Standard**

CE cULus N1971

Complies with major world standards (CE marking, UL, cUL, C-tick)

**ISO 9001:** VF-S9 series is manufactured at the works, which has received the international quality assurance standard ISO 9001 certification.

The works producing the VF-S9 series is registered as an environment management system factory specified by ISO 14001.

## 1

### For System Designers ...

#### Flexible Selections Excellent basic performance and diverse functions allow operations as needed.

- Sensorless vector control provides the startup torque of 150% or more. The "Auto-tuning function" allows setting motor constants without rotating the motor.
- Wide capacity range (0.2 to 15 kW) is provided even for this compact class.
- Compatible with various power voltages. The single-phase input model inputs 200V to 240V, the three-phase 400V model inputs 380V to 500V.
- The control circuit I/O logic (Sink/Source) is switched by one-touch operation. Many types of programmable controllers are easily connected.

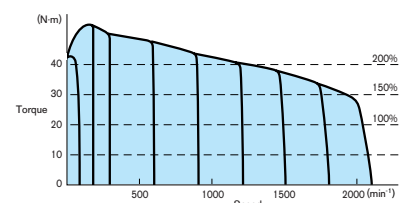

■ Capacity Range

Voltage Class (Input/Rated Output)	Applicable Motor Capacity (kW)									
	0.2	0.4	0.75	1.5	2.2	3.7	5.5	7.5	11	15
1φ200V/3φ200V	[Bar chart showing capacity range]									
3φ200V/3φ200V	[Bar chart showing capacity range]									
3φ400V/3φ400V	[Bar chart showing capacity range]									

## 2

### For Manufacturers ...

#### Easy Installation

EMI noise, audible noise, and installation space problems are solved.

- All models have EMI noise filter inside, significantly reducing noise emissions.
- EMC plate (attached as standard) shields the wiring to further suppress radiated EMI noise.
- Side-by-side installation saves space. Multiple units can be installed without side clearance. For example, installing five units of VFS9-2007PM side by side requires only 60% of the area for conventional inverters.
- Optional DIN rail kit allows one-touch installation (models of 200V class 0.75kW or less).
- Availability of high carrier frequency setting reduces audible motor noise. Even if the carrier frequency is set to a low level to suppress the EMI noise influence, the newly developed "Random Mode Carrier Frequency" can soften audible noise.
- Foot-mount type filter for space-saving is provided as option to comply with the EN standard.

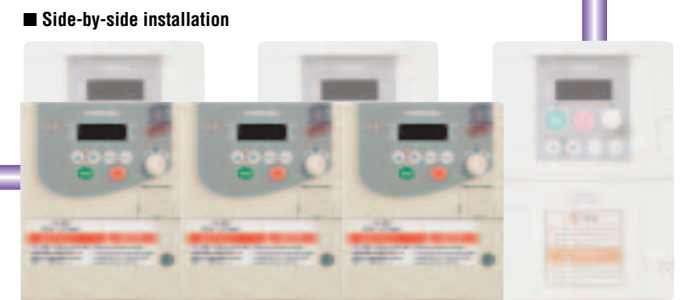
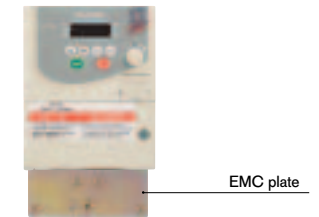
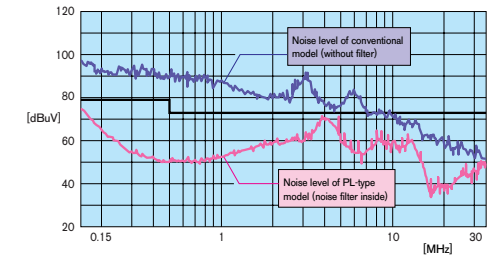

Installation of VF-S9      Conventional models

## 3

### For Users ...

#### Easy Setting

Users can easily make settings and operate reliably.

- Switches and potentiometer dial on the front panel allow immediate and easy operation.
- The enhanced "Automatic Setting Functions" enable easy and convenient set up. Automatic acceleration/deceleration, Automatic torque boost, Automatic environment setting, Automatic function setting, reduce start up time.
- Diverse functions are conveniently enhanced.
  - Relay contact output: 1 c-contact + 1 a-contact (+ 1 open collector output) is provided.
  - Programmable I/O terminals: 6 input terminals and 3 output terminals can be selected from 51 input types and 30 output types of menus.
  - Meter analog output: Analog output signal can be selected from 6 types of menus. 0-10V and 4-20mA signal can also be switched by one-touch operation.
- Enhanced protective functions assure reliable operation.
  - I/O phase failure detecting, earth fault detecting function.
  - Dependable operation in case of power voltage drop.
  - Reliable continuous operation secured by auto-restart control function and regenerative power ride-through control function.

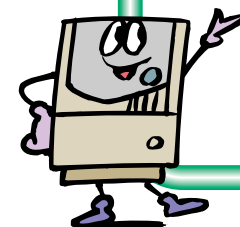

### Contents

Panel and Operation Method	3-4
Standard Specifications and External Dimensions	5-6
Functional Description	7-8
Connection Diagram and Selection of Wiring Devices	9
Terminal Functions	10
Inverter Q & A	11-13
To Users of Our Inverters	14-16
Optional external devices	17-21
Trip Display and Alarm Display	22

# Panel and Operation Method

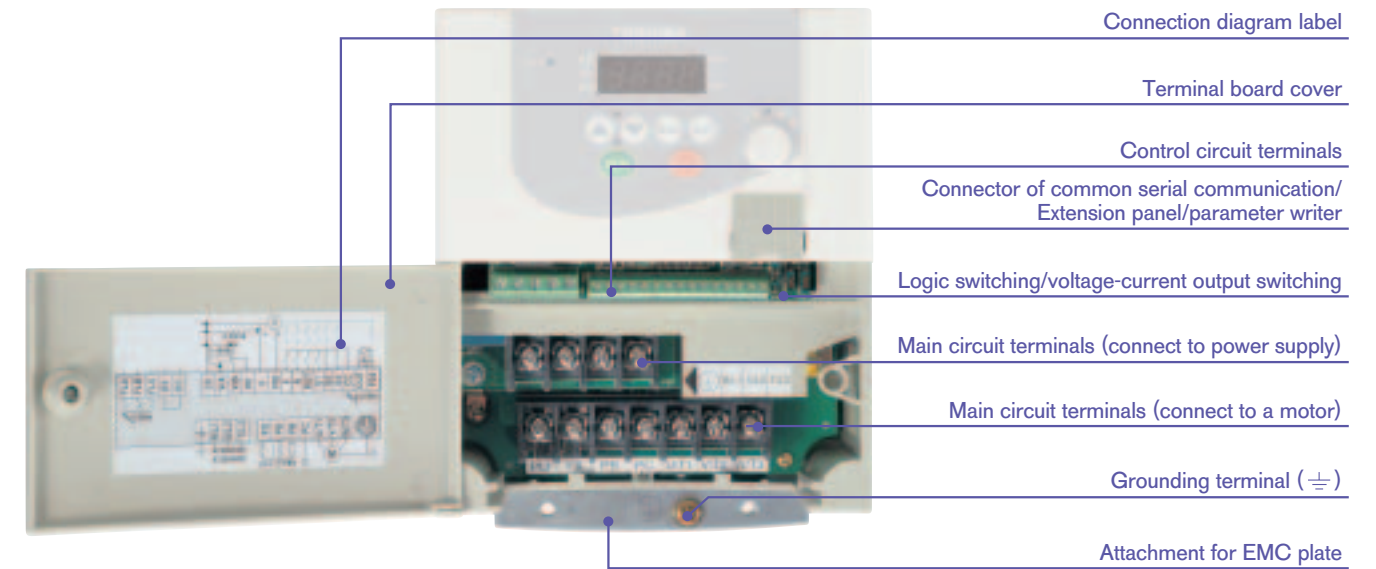
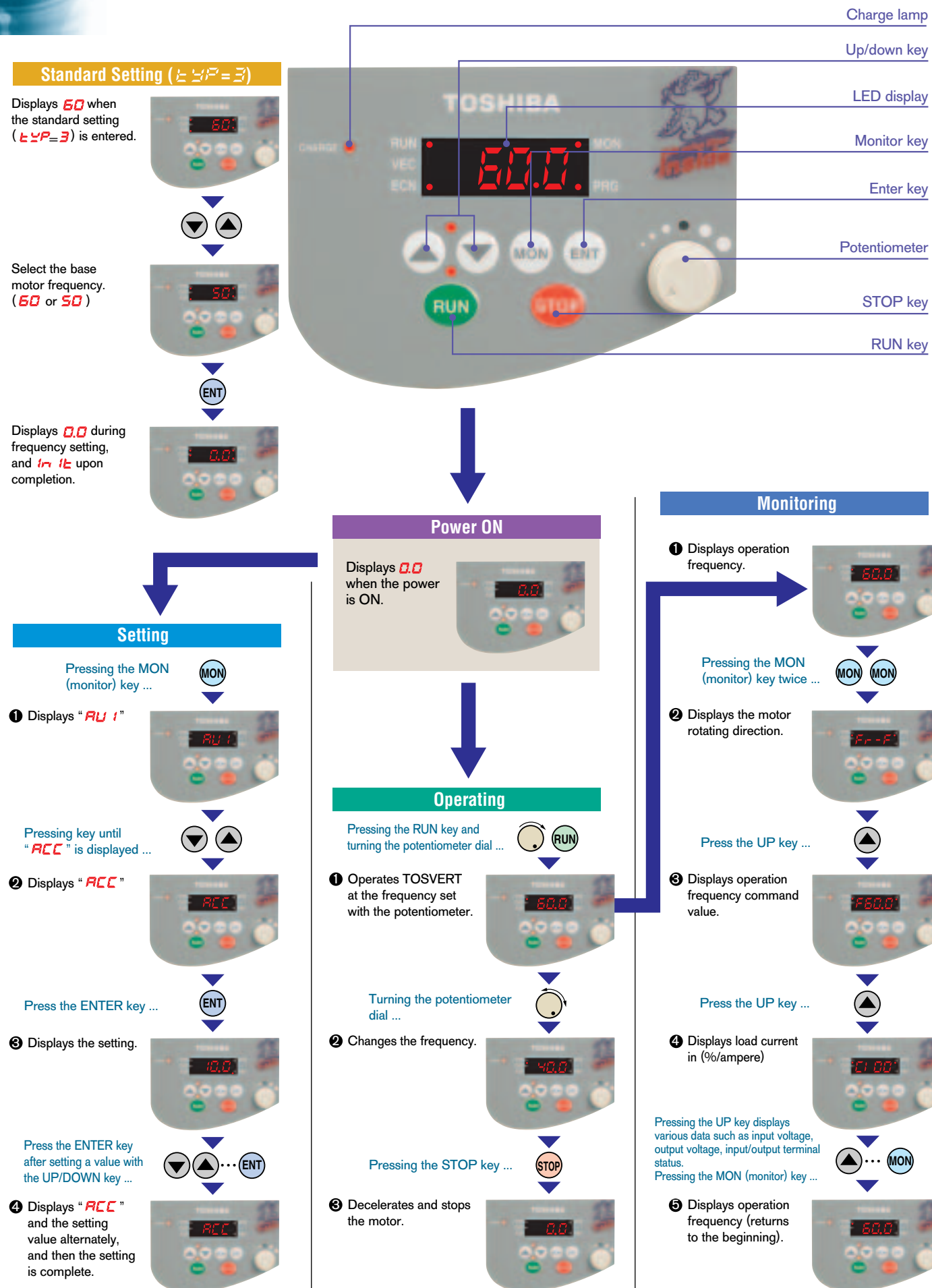

## Monitoring — Status monitor mode

In this mode, you can monitor the operational status of the inverter. To display the operation status during normal operation: Press the **(MON)** key twice.

**Setting procedure (eg. operation at 60Hz)**

Item displayed	Key operated	LED display	Description
		60.0	The operation frequency is displayed (during operation). (When the standard monitor display selection parameter F7.10 is set at 0 [operation frequency])
Parameter setting mode	(MON)	AU 1	The first basic parameter "Automatic acceleration/ deceleration (AU 1)" is displayed.
Operation frequency	(MON)	F60.0	The operation frequency is displayed (during operation).
Direction of rotation	(▲)	F - F	The direction of rotation is displayed. (F: forward run, r: reverse run)
Operation frequency command	(▲)	F60.0	The operation frequency command value is displayed.
Load current	(▲)	C80	The inverter output current (load current) is displayed.
Input voltage	(▲)	V100	The inverter input voltage is displayed. (Default setting: unit %)
Output voltage	(▲)	P100	The inverter output voltage is displayed. (Default setting: unit %)
Input terminal	(▲)	R1111	The ON/OFF status of each of the control signal input terminals (F, R, RST, S1, S2 and S3) is displayed in bits. ON: R1111 OFF: 0111
Output terminal	(▲)	0111	The ON/OFF status of each of the control signal output terminals (RY, OUT and FL) is displayed in bits. ON: R1111 OFF: 0111

Item displayed	Key operated	LED display	Description
CPU version	(▲)	V101	The version of the CPU is displayed.
Memory version	(▲)	ME100	The version of the memory mounted is displayed.
Past trip 1	(▲)	OC3 ↔ 1	Past trip 1 (displayed alternately at 0.5-sec. intervals)
Past trip 2	(▲)	OH ↔ 2	Past trip 2 (displayed alternately at 0.5-sec. intervals)
Past trip 3	(▲)	OP3 ↔ 3	Past trip 3 (displayed alternately at 0.5-sec. intervals)
Past trip 4	(▲)	nErr ↔ 4	Past trip 4 (displayed alternately at 0.5-sec. intervals)
Cumulative operation time	(▲)	t0.10	The cumulative operation time is displayed. (0.01 corresponds to 1 hours.)
Torque current	(▲)	t88	The torque current is displayed in %.
PI feedback	(▲)	d50	The PI feedback value is displayed. (Unit: processed amount)
Inverter load factor	(▲)	L80	The inverter load factor is displayed in %.
PBR overload factor	(▲)	r80	The overload factor of the braking resistor is displayed in %.
Output power	(▲)	H3.7	The inverter output power is displayed in %.
Default display mode	(MON)	60.0	The operation frequency is displayed (during operation).

Note) 1. With the current unit selection parameter or voltage unit selection parameter, you can choose between percentage and ampere (A) for current or between percentage and volt (V) for voltage, respectively.

## Contents of the product code

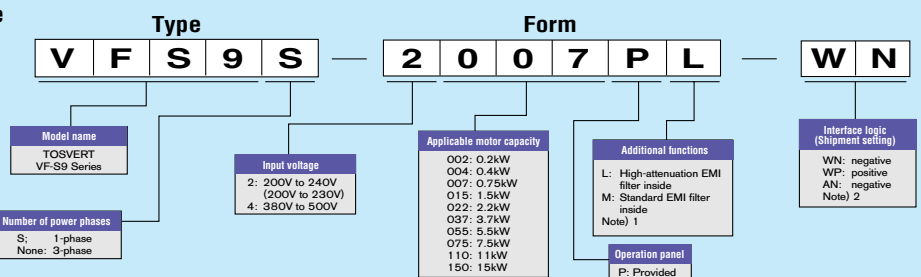

Note) 1. L: Standard model without optional filter conform to "EN55011 Group 1 Class A"  
With Foot-mounted noise filter conform to "EN55011 Group 1 Class B"  
M: With Foot-mounted noise filter conform to "EN55011 Group 1 Class A"

Note) 2. Interface logic can be switched easily.

# Standard Specifications and External Dimensions

## Model and standard specifications

Item		Specification									
Input voltage		3-phase 200V									
Applicable motor (kW)		0.2	0.4	0.75	1.5	2.2	3.7	5.5	7.5	11	15
Rating	Type	VFS9 -									
	Form	2002PM	2004PM	2007PM	2015PM	2022PM	2037PM	2055PL	2075PL	2110PM	2150PM
	Capacity (kVA) Note 1)	0.6	1.3	1.8	3.0	4.2	6.7	10	13	21	25
	Rated output current (A) Note 2)	1.5	3.3	4.8	7.8	11.0	17.5	27.5	33	54	66
	Rated output voltage Note 3)	3-phase 200V to 230V									
Overload current rating		60 seconds at 150%, 0.5 seconds at 200%									
Power supply	Voltage-frequency	3-phase 200V to 230V - 50/60Hz									
	Allowable fluctuation	Voltage +10%, -15% Note 4), frequency ±5%									
Protective method		IP20 Enclosed type (JEM1030)									
Cooling method		Self cooling	Forced air-cooled								
Color		Munsel 5Y-8/0.5									
Built-in filter		Standard EMI filter					High-attenuation EMI filter			Standard EMI filter	

Item		Specification												
Input voltage		1-phase 200V						3-phase 400V						
Applicable motor (kW)		0.2	0.4	0.75	1.5	2.2	0.75	1.5	2.2	3.7	5.5	7.5	11	15
Rating	Type	VFS9S -						VFS9 -						
	Form	2002PL	2004PL	2007PL	2015PL	2022PL	4007PL	4015PL	4022PL	4037PL	4055PL	4075PL	4110PL	4150PL
	Capacity (kVA) Note 1)	0.6	1.3	1.8	3.0	4.2	1.8	3.1	4.2	7.2	11	13	21	25
	Rated output current (A) Note 2)	1.5	3.3	4.8	7.8	11.0	2.3	4.1	5.5	9.5	14.3	17.0	27.7	33
	Rated output voltage Note 3)	3-phase 200V to 240V						3-phase 380V to 500V						
Overload current rating		60 seconds at 150%, 0.5 seconds at 200%						60 seconds at 150%, 0.5 seconds at 200%						
Power supply	Voltage-frequency	3-phase 200V to 240V - 50/60Hz						3-phase 380V to 500V - 50/60Hz						
	Allowable fluctuation	Voltage +10%, -15% Note 4), frequency ±5%						Voltage +10%, -15% Note 4), frequency ±5%						
Protective method		IP20 Enclosed type (JEM1030)						IP20 Enclosed type (JEM1030)						
Cooling method		Self cooling	Forced air-cooled				Forced air-cooled							
Color		Munsel 5Y-8/0.5						Munsel 5Y-8/0.5						
Built-in filter		High-attenuation EMI filter												

Note) 1. Capacity is calculated at 220V for the 200V models and at 440V for the 400V models.  
 2. Indicates rated output current setting when the PWM carrier frequency (parameter F300) is 4kHz or less. When exceeding 4kHz, the rated output current setting is indicated in the parenthesis. When the input power voltage of the 400V class model exceeds 480V, it is necessary to further reduce the setting. The default setting of the PWM carrier frequency is 12kHz.

Note) 3. Maximum output voltage is the same as the input voltage.  
 4. ±10% when the inverter is used continuously (load of 100%).

## Standard Specifications

Item		Specification
Principal control functions	Control system	Sinusoidal PWM control
	Rated output voltage	Adjustable within a range of 100 to 120% of the corrected supply voltage (200/400V) (Unadjustable to any voltage higher than the input voltage).
	Output frequency range	0.5 to 400Hz, default setting: 0.5 to 60Hz, maximum frequency: 30 to 400Hz.
	Minimum setting steps of frequency	0.1Hz: operation panel setting, 0.2Hz: analog input (when the max. frequency is 100Hz).
	Frequency accuracy	Digital setting: within ±0.01% of the max. frequency (-10 to +50°C). Analog setting: within ±0.5% of the max. frequency (25°C±10°C).
	Voltage/frequency characteristics	V/f constant, variable torque, vector control, automatic torque boost, Base frequency and torque boost amount adjustable.
Operation specifications	Frequency setting signal	Front potentiometer and external potentiometer (rated impedance of connectable potentiometer: 1 to 10kΩ), 0 to 10Vdc (input impedance: VIA=30.55 kΩ, VB=30 kΩ), 4 to 20mAdc (input impedance: 400Ω). The characteristic can be set arbitrarily by two-point setting.
	Start-up frequency/frequency jump	Adjustable within a range of 0 to 10Hz / Up to 3 frequencies can be adjusted together with their widths.
	PWM carrier frequency (Note 1)	Adjustable within a range of 2.0 to 16.5Hz (default: 12kHz).
	Acceleration/deceleration time	0.1 to 3600 seconds, switchable between acceleration/deceleration time 1 and 2, selectable between S-pattern acceleration/deceleration 1 and 2.
	Retry operation	Restart after a check of the main circuit elements in case the protective function is activated: 10 times (Max.) (adjustable with a parameter).
	Dynamic braking	With a built-in dynamic braking circuit, external braking resistor available (optional).
	DC braking	Braking start-up frequency: 0 to maximum frequency, braking rate: 0 to 100%, braking time: 0 to 20 seconds.
	Input terminal functions (selectable)	Forward/reverse run input signal, jog run input signal, standby signal, preset-speed operation input signal, reset input signal, etc. / Switching between sink/source.
	Output terminal functions (selectable)	Frequency lower limit output signal, frequency upper limit output signal, low-speed detection output signal, specified speed attainment output signal, etc. Open collector, RY output.
	Failure detection signal	1c-contact output: 250Vac/2A, cosφ = 0.1, 250Vac/1A, cosφ = 0.4, 3Vdc/1A.
Protective function	Output for frequency meter/output for ammeter	Analog output: (1mAdc full-scale DC ammeter or 7.5Vdc full-scale DC ammeter / Rectifier-type AC voltmeter, 225% current Max. 1mAdc, 7.5Vdc full-scale), 4 to 20mA/0 to 20mA output.
	Protective function	Stall prevention, current limitation, over-current, output short circuit, over-voltage, over-voltage limitation, undervoltage, ground fault, power supply phase failure, output phase failure overload protection by electronic thermal function, armature over-load at start-up (5.5kW or larger), load-side over-torque at start, pre-alarm, overheat.
	Protection against momentary power failure	Auto-restart/non-stop control after momentary power failure.
Display function	Electronic thermal characteristic	Switching between standard motor/constant-torque VF motor, overload trip, overload stall selection.
	4-digit 7-segments LED	Frequency: inverter output frequency. Alarm: stall alarm "C", overvoltage alarm "P", overload alarm "L", overheat alarm "H". Status: inverter status (frequency, cause of activation of protective function, input/output voltage, output current, etc.) and parameter settings. Free-unit display: arbitrary unit (e.g. rotating speed) corresponding to output frequency.
Environments	Indicator	Lamps indicating the inverter status by lighting, such as RUN lamp, MON lamp, PRG lamp, VEC lamp, ECN lamp, frequency setting potentiometer lamp, UP/DOWN key lamp and RUN key lamp. The charge lamp indicates that the main circuit capacitors are electrically charged.
	Use environments	Indoor, altitude: 1000m (Max.), not exposed to direct sunlight, corrosive gas, explosive gas or vibration (less than 5.9m/s <sup>2</sup> ) (10 to 55Hz).
Environments	Ambient temperature	-10 to +60°C Note)1,2,3
	Storage temperature	-20 to +65°C
	Relative humidity	20 to 93% (free from condensation and vapor).

Note) 1. Above 40°C : Remove the protective seal from the top of VF-S9.  
 2. Above 50°C : Remove the protective seal from the top of VF-S9, and derate the rated output current by 3% for every °C above 50°C  
 3. Side-by-side installation  
 - Model of 3.7kW or less : from -10°C to 40°C (Remove the protective seal from the top of VF-S9.)  
 - Model of 5.5kW or more : from -10°C to 50°C

## Outline drawing

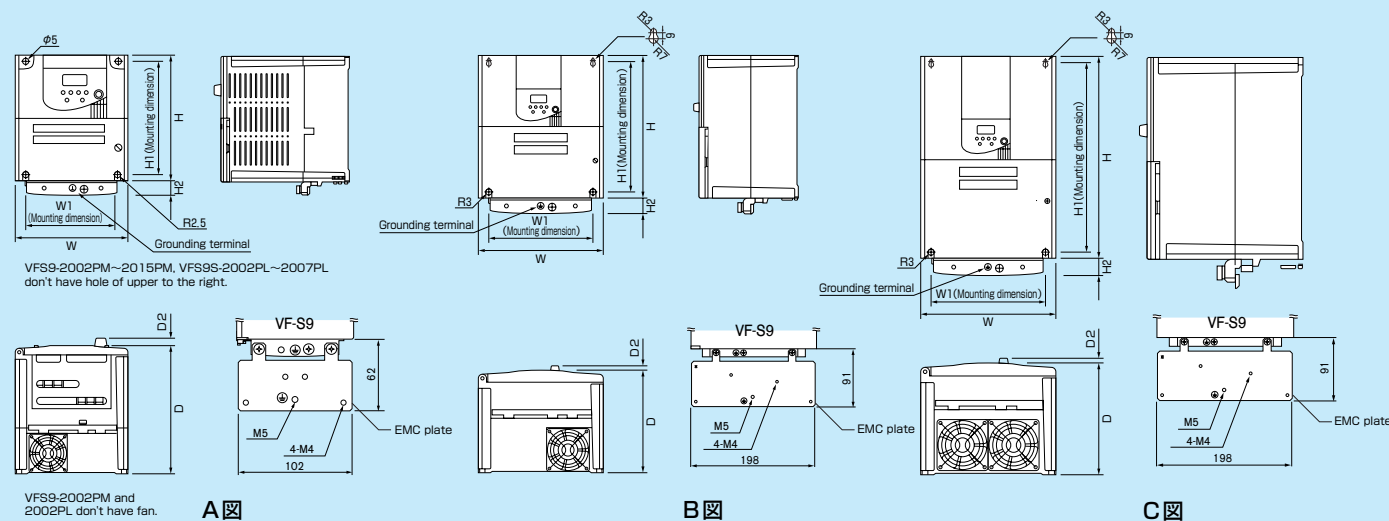

## External dimensions/weights

Input voltage	Applicable motor (kW)	Type	Dimensions (mm)							Drawing	Approx. weight (kg)
			W	H	D	W1	H1	H2	D2		
1-phase 200V	0.2	VFS9S-2002PL	105	130	140	93	118	14	8.5	A	1.2
	0.4	VFS9S-2004PL									1.3
	0.75	VFS9S-2007PL									1.3
	1.5	VFS9S-2015PL									1.8
	2.2	VFS9S-2022PL									2.8
	15	VFS9S-2150PM									2.8
3-phase 200V	0.2	VFS9-2002PM	105	130	130	93	118	14	8.5	A	1.1
	0.4	VFS9-2004PM									1.2
	0.75	VFS9-2007PM									1.2
	1.5	VFS9-2015PM									1.4
	2.2	VFS9-2022PM									2.3
	3.7	VFS9-2037PM									2.5
	5.5	VFS9-2055PL									6.2
	7.5	VFS9-2075PL									6.3
	11	VFS9-2110PM									9.8
	15	VFS9-2150PM									9.9
3-phase 400V	0.75	VFS9-4007PL	130	150	150	118	138	14	8.5	A	1.8
	1.5	VFS9-4015PL									1.9
	2.2	VFS9-4022PL									2.7
	3.7	VFS9-4037PL									2.9
	5.5	VFS9-4055PL									6.3
	7.5	VFS9-4075PL									6.3
	11	VFS9-4110PL									9.8
	15	VFS9-4150PL									9.8

# Function Description

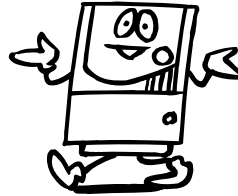

## What are parameters?

Each "setting item" that determines the control (operation) of an inverter is called a parameter. For example, the connection meter selection parameter (title **FNSL**) is adjusted to set the connection meter, the acceleration time parameter (title **FCC**) is adjusted to change the acceleration time, and the maximum frequency parameter (title **FH**) is adjusted to modify the maximum frequency. For the function you want to use, check the necessary parameter(s).

### Basic parameters

#### Four automatic functions

Title	Function	Unit	Adjustment range	Default setting	MEMO
<b>FU1</b>	Automatic acceleration/deceleration	-	0: Disabled (manual) 1: Optimum rate 2: Minimum rate	0	
<b>FU2</b>	Automatic torque boost	-	0: Disabled 1: Sensorless Vector control + auto-tuning	0	
<b>FU3</b>	Automatic environment setting	-	0: Disabled 1: Automatic setting	0	
<b>FU4</b>	Automatic function setting	-	0: Disabled 1: Coast stop 2: 3-wire operation 3: External input UP/DOWN setting 4: 4-20mA current input operation	0	

Note) 1. In case of the model of Type-form "-WN", default setting of parameter **UL**, **UL**, **F170**, **F204**, and **F213** are 60 (Hz). In case of "-WP", these parameter are 50 (Hz).  
2. The setting varies with the inverter capacity.  
3. Display units are changed by the setting of parameter **F701** (unit selection).  
4. If 3 or 4 is set for parameter **F200** (frequency priority selection), the parameter function at the lower stage is active for **F210** to **F213**.

### Setup parameters

When the standard setting (**FYP=3**) is entered, the following parameter is displayed. Be sure to make that setting.

Title	Function	Unit	Adjustment range	Default setting	MEMO
-	Applicable motor base frequency	Hz	60 50	*1	

Note) Make settings suitable for the applicable motor base frequency (reference frequency at rated torque of motor).

### How to read the monitor display?

#### Monitor display

The LEDs on the operation panel display the following symbols to indicate operations and parameters.

#### LED (number)

0	1	2	3	4	5	6	7	8	9	-
0	1	2	3	4	5	6	7	8	9	-

#### Other basic parameters

Title	Function	Unit	Adjustment range	Default setting	MEMO
<b>CNDd</b>	Command mode selection	-	0: Terminal board 1: Operation panel	1	
<b>FNDd</b>	Frequency setting mode selection	-	0: Terminal board 1: Operation panel 2: Internal potentiometer 3: Serial communication	2	
<b>FNSL</b>	Meter selection	-	0: Output frequency 1: Output current 2: Set frequency 3: For adjustment (current fixed at 100%) 4: Inverter load factor 5: Output power 6: Torque current 7: PBr load factor 8: PN voltage 9: Output voltage command 10: Frequency of VIA 11: Frequency command after PI	0	
<b>FN</b>	Meter adjustment	-	-	-	
<b>FYP</b>	Standard setting mode selection	-	0: -(invalid) 1: 50 Hz setting 2: 60 Hz setting 3: Default setting 4: Trip clear 5: Cumulative operation time clear 6: Initialization of type information	0	
<b>Fp</b>	Forward/reverse run selection (Operation panel)	-	0: Forward run 1: Reverse run	0	
<b>FCC</b>	Acceleration time 1	s	0.1 - 3600	10.0	
<b>DEC</b>	Deceleration time 1	s	0.1 - 3600	10.0	
<b>FH</b>	Maximum frequency	Hz	30.0 - 400	80.0	
<b>UL</b>	Upper limit frequency	Hz	0.5 - <b>FH</b>	*1	
<b>LL</b>	Lower limit frequency	Hz	0.5 - <b>UL</b>	0.0	
<b>UL</b>	Base frequency 1	Hz	25 - 400	*1	
<b>Ft</b>	V/F control mode selection	-	0: V/F constant 1: Variable torque 2: Automatic torque boost 3: Sensorless vector control 4: Automatic energy-saving 5: Sensorless vector control (VFS7 mode)	0	
<b>ub</b>	Torque boost	%(V)	0.0 - 30.0 *3	*2	
<b>thp</b>	Motor electronic-thermal protection level 1	%(A)	10 - 100 *3	100	
<b>OLn</b>	Electronic-thermal protection characteristic selection	-	Setting Type Overload protection OL stall 0 Standard motor valid invalid 1 Standard motor valid invalid 2 Standard motor invalid invalid 3 Standard motor invalid valid 4 V/F motor (special motor) valid invalid 5 V/F motor (special motor) valid invalid 6 V/F motor (special motor) invalid invalid 7 V/F motor (special motor) invalid valid	0	
<b>Sr1</b> <b>Sr7</b>	Preset-speed operation frequencies 1 to 7	Hz	<b>LL - UL</b>	0.0	
<b>F--</b>	Extended parameter	-	-	-	
<b>Gr.U</b>	Automatic edit function	-	-	-	

#### LED (alphabet)

Aa	Bb	Cc	Dd	Ee	Ff	Gg	Hh	Ii	Jj	Kk	Ll	Mm
<b>A</b>	<b>b</b>	<b>C</b>	<b>d</b>	<b>E</b>	<b>F</b>	<b>G</b>	<b>H</b>	<b>i</b>	<b>J</b>	<b>K</b>	<b>L</b>	<b>M</b>
Nn	Oo	Pp	Qq	Rr	Ss	Tt	Uu	Vv	Ww	Xx	Yy	Zz
<b>n</b>	<b>O</b>	<b>P</b>	<b>q</b>	<b>R</b>	<b>S</b>	<b>t</b>	<b>U</b>	<b>v</b>	<b>W</b>	<b>X</b>	<b>Y</b>	<b>Z</b>

## Extended parameters

### Input/output parameters

Title	Function	Unit	Adjustment range	Default setting	MEMO
<b>F100</b>	Low-speed signal output frequency	Hz	0.0 - <b>FH</b>	0.0	
<b>F101</b>	Speed reach setting frequency	Hz	0.0 - <b>FH</b>	0.0	
<b>F102</b>	Speed reach detection band	Hz	0.0 - <b>FH</b>	2.5	
<b>F103</b>	ST signal selection	-	0: Stand by on when ST is on 1: Stand by always on 2: Interlocked with F/R 3: Stand by on when ST is off	1	
<b>F104</b>	RST signal selection	-	0: Default 1: Activated by turning RST off	0	
<b>F105</b>	Movement of F/R input at same time	-	0: Reverse run 1: Stop	0	
<b>F110</b>	Always-active function selection	-	0 - 53	0	
<b>F111</b>	Input terminal selection 1 (F)	-	0 - 53 (F)	2	
<b>F112</b>	Input terminal selection 2 (R)	-	0 - 53 (R)	3	
<b>F113</b>	Input terminal selection 3 (RST)	-	0 - 53 (RST)	10	
<b>F114</b>	Input terminal selection 4 (S1)	-	0 - 53 (SS1)	6	
<b>F115</b>	Input terminal selection 5 (S2)	-	0 - 53 (SS2)	7	
<b>F116</b>	Input terminal selection 6 (S3)	-	0 - 53 (SS3)	8	
<b>F130</b>	Output terminal selection 1 (RY-RC)	-	0 - 41 (LOW)	4	
<b>F131</b>	Output terminal selection 2 (OUT)	-	0 - 41 (RCH)	6	
<b>F132</b>	Output terminal selection 3 (FL)	-	0 - 41 (FL)	10	
<b>F170</b>	Base frequency 2	Hz	25 - 400	*1	
<b>F172</b>	Torque boost 2	%(V)	0.0 - 30.0 *3	*2	
<b>F173</b>	Motor electronic-thermal protection level 2	%(A)	0.0 - 30.0 *3	100	
<b>F200</b>	Frequency priority selection	-	0: VIA/II, VIB, 1: VIB, VIA/II 2: External switching (FCHG enabled) 3: External contact UP/DOWN *4 4: External contact UP/DOWN *4 (Setting retained even if the power is turned off) 5: VIA/II-VIB	0	
<b>F201</b>	VIA/II input point 1 setting	%	0 - 100	0	
<b>F202</b>	VIA/II input point 1 frequency	Hz	0.0 - 400.0	0.0	
<b>F203</b>	VIA/II input point 2 setting	%	0 - 100	100	
<b>F204</b>	VIA/II input point 2 frequency	Hz	0.0 - 400.0	*1	
<b>F210</b>	VIB input point 1 setting	%	0 - 100	0	
<b>F211</b>	VIB input point 1 frequency	Hz	0.0 - 400.0	0	
<b>F212</b>	VIB input point 2 setting	%	0 - 100	100	
<b>F213</b>	VIB input point 2 frequency	Hz	0 - 400	*1	
<b>F240</b>	Starting frequency setting	Hz	0.5 - 10.0	0.5	
<b>F241</b>	Operation starting frequency	Hz	0.0 - <b>FH</b>	0.0	
<b>F242</b>	Operation starting frequency hysteresis	Hz	0.0 - <b>FH</b>	0.0	
<b>F250</b>	DC braking starting frequency	Hz	0.0 - 20.0	0.0	
<b>F251</b>	DC braking current	%(A)	0 - 100	30	
<b>F252</b>	DC braking time	s	0.0 - 20.0	1.0	
<b>F254</b>	Motor shaft fixing control	-	0: Disabled, 1: Enabled	0	
<b>F256</b>	Auto stop of continuous running at LL	-	0: Disabled, 0.1-25.5	0	
<b>F260</b>	Jog run frequency	Hz	0.0 - 20.0	0.0	
<b>F261</b>	Jog run stopping pattern	-	0: Slowdown stop, 1: Coast stop 2: DC braking 3: Slowdown stop (panel jog mode) 4: Coast stop (panel jog mode) 5: DC braking (panel jog mode)	0	
<b>F270</b>	Jumping frequency 1	Hz	<b>LL - UL</b>	0.0	
<b>F271</b>	Jumping width 1	Hz	0.0 - 30.0	0.0	
<b>F272</b>	Jumping frequency 2	Hz	<b>LL - UL</b>	0.0	
<b>F273</b>	Jumping width 2	Hz	0.0 - 30.0	0.0	
<b>F274</b>	Jumping frequency 3	Hz	<b>LL - UL</b>	0.0	
<b>F275</b>	Jumping width 3	Hz	0.0 - 30.0	0.0	
<b>F280</b> <b>F294</b>	Preset-speed operation frequencies 1 to 15	Hz	<b>LL - UL</b>	0.0	

### Operation mode parameters

Title	Function	Unit	Adjustment range	Default setting	MEMO
<b>F300</b>	PWM carrier frequency	kHz	2.0 - 16.5	12.0	
<b>F301</b>	Auto-restart control selection	-	0: Disabled 1: At auto-restart after momentary stop 2: When turning ST-CC on or off 3: At auto-restart or when turning ST-CC on or off 4: Motion of DC braking at start-up (at auto-restart after momentary stop) 5: Motion of DC braking at start-up (when turning ST-CC on or off) 6: Motion of DC braking at start-up (at auto-restart or when turning ST-CC on or off) 7-13: See the instruction manual	0	
<b>F302</b>	Regenerative power ride-through control	-	0: Disabled, 1: Enabled 2: Enabled(deceleration stop)	0	
<b>F303</b>	Retry selection (number of times)	Times	0 - 10	0	
<b>F304</b>	Dynamic braking selection	-	0: Dynamic braking disabled 1: Dynamic braking enabled, overload protection disabled 2: Dynamic braking enabled, overload protection enabled	0	
<b>F305</b>	Overvoltage stall operation	-	0: Enabled, 1: Disabled 2: Enabled(quick deceleration with overexcitation)	0	
<b>F306</b>	Output voltage adjustment (Base frequency voltage)	V	0 - 300 / 0 - 600	200/400	
<b>F307</b>	Supply voltage compensation	-	0: Supply voltage uncorrected, output voltage limited 1: Supply voltage corrected, output voltage limited 2: Supply voltage corrected (off during deceleration), output voltage limited 3: Supply voltage uncorrected, output voltage unlimited 4: Supply voltage corrected, output voltage limited 5: Supply voltage corrected (off during deceleration), output voltage unlimited	3	
<b>F308</b>	Braking resistor operation rate	%ED	1 - 100	3	
<b>F312</b>	Random mode	-	0: Disabled, 1: Enabled	0	
<b>F319</b>	Voltage gain of overexcitation	-	0-255	*1	
<b>F320</b>	Drooping gain	%	0-25.0	0.0	
<b>F323</b>	Drooping insensitive torque band	%	0-100	100	

<b>F360</b>	PI control	-	0: Disabled, 1: Enabled	0	
<b>F362</b>	Proportional gain	-	0.01 - 100.0	0.30	
<b>F363</b>	Integral gain	-	0.01 - 100.0	0.20	

### Torque boost parameters

Title	Function	Unit	Adjustment range	Default setting	MEMO
<b>F400</b>	Auto-tuning	-	0: Auto-tuning disabled (use of internal parameters) 1: Application of individual settings of <b>F401</b> to <b>F405</b> 2: Auto-tuning enabled (returns to 1 after auto-tuning)	0	
<b>F401</b>	Slip frequency	Hz	0.0 - 10.0	*2	
<b>F402</b>	Motor primary constant	-	0 - 255	*2	
<b>F403</b>	Motor secondary constant	-	0 - 255	*2	
<b>F404</b>	Motor excitation constant	-	0 - 255	*2	
<b>F405</b>	Magnification of load inertial moment	Times	0 - 200	0	
<b>F408</b>	Rated capacity ratio of motor to inverter	-	0: Same capacity as inverter 1: One-size smaller than inverter	0	
<b>F409</b>	Torque current filter	-	0 - 8	2	

### Acceleration/deceleration time parameters

Title	Function	Unit	Adjustment range	Default setting	MEMO
<b>F500</b>	Acceleration time 2	s	0.1 - 3600	10.0	
<b>F501</b>	Deceleration time 2	s	0.1 - 3600	10.0	
<b>F502</b>	Acceleration/deceleration 1 pattern	-	0: Linear 1: S-pattern 1 2: S-pattern 2	0	
<b>F503</b>	Acceleration/deceleration 2 pattern	-	0: Linear 1: S-pattern 1 2: S-pattern 2	0	
<b>F504</b>	Acceleration/deceleration pattern selection (1 or 2)	-	0: Acceleration/deceleration 1 1: Acceleration/deceleration 2	0	
<b>F505</b>	Acceleration/deceleration 1 and 2 switching frequency	Hz	0 - <b>UL</b>	0.0	

### Protection parameters

Title	Function	Unit	Adjustment range	Default setting	MEMO
<b>F600</b>	Motor electronic-thermal protection level 1	%(A)	10 - 100 *3	100	
<b>F601</b>	Stall prevention level	%(A)	10 - 199, 200 (disabled) *3	150	
<b>F602</b>	Inverter trip retention selection	-	0: Not retained, 1: Retained	0	
<b>F603</b>	External input trip stop mode selection	-	0: Coast stop, 1: Slowdown stop 2: Emergency DC braking	0	
<b>F604</b>	Emergency DC braking time	s	0.0 - 20.0	1.0	
<b>F605</b>	Output phase failure detection mode selection	-	0: Disabled, 1: Enabled	0	
<b>F608</b>	Input phase failure detection mode selection	-	0: Disabled, 1: Enabled	1	
<b>F610</b>	Small current trip selection	-	0: Disabled, 1: Enabled	0	
<b>F611</b>	Small current (trip/alarm) detectin current	%	0 - 100	0	
<b>F612</b>	Small current (trip/alarm) detectin time	s	0 - 255	0	
<b>F613</b>	Selection of output short-circuit detection pulse during start-up	-	0: Disabled, 1: Enabled 1: 60usec, every start to run 2: 30usec, every start to run 3: 30usec, only at power on or reset	0	
<b>F615</b>	Over-torque trip selection	-	0: Disabled, 1: Enabled	0	
<b>F616</b>	Over-torque (trip/alarm) level	%	0 - 250	150	
<b>F618</b>	Over-torque detection time	s	0 - 10	0.5	
<b>F619</b>	Over-torque (trip/alarm) level hysteresis	%	0 - 100	10	
<b>F626</b>	Overvoltage limit operation level	%	50 - 150	*1	
<b>F627</b>	Undervoltage trip selection	-	0: Disabled 1: Enabled (at 70% or less) 2: Disabled (at 50% or less, optional soon to be released)	0	
<b>F633</b>	VIA analog input line break detection	%	0: Disabled, 1-100%	0	
<b>F632</b>	Meter bias	%	0 - 50	0	

### Operation panel parameters

Title	Function	Unit	Adjustment range	Default setting	MEMO
<b>F700</b>	Prohibition of change of parameter settings	-	settings: RUN/STOP key Parameter setting Parameter Change Parameter setting	0	
			0 effective Permit impossible --- 1 effective Prohibit --- Prohibit 2 effective Permit possible --- 3 effective Prohibit --- Permit 4 Prohibit Permit impossible --- 5 Prohibit Prohibit --- Prohibit 6 Prohibit Permit possible --- 7 Prohibit Prohibit --- Permit		
<b>F701</b>	Unit selection	-	0: No change 1: % → A (ampere)/V (volt) 2: Free unit selection enabled ( <b>F702</b> ) 3: % → A (ampere)/V (volt) Free unit selection enabled ( <b>F702</b> )	0	
<b>F702</b>	Free unit selection	-	0.01 - 200.0	1.00	
<b>F710</b>	Standard monitor display selection	-	0: Operation frequency (Hz/free unit) 1: Output current (%A) 2: Frequency command (Hz/free unit) 3: Inverter rate current (A) 4: Inverter over load factor (%) 5: Output power (%) 6: After compensation frequency (Hz/free unit)	0	

### Communication parameters

Title	Function	Unit	Adjustment range	Default setting	MEMO
<b>F800</b>	Communication band speed	-	0: 1200bps 1: 2400 bps 2: 4800 bps 3: 9600 bps 4: 19200bps	3	
<b>F801</b>	Parity	-	0: NON 1: EVEN 2: ODD	1	
<b>F802</b>	Inverter number	-	0 - 255	0	
<b>F803</b>	Communication error trip time	s	0 (Disabled), 1 - 100	0	
<b>F805</b>	Communication internal	s	0.00 - 2.00	0.00	
<b>F806</b>					

# Connection Diagram and Selection of Wiring Devices

# Terminal Functions

## Standard connection diagram

Sink (common: CC)

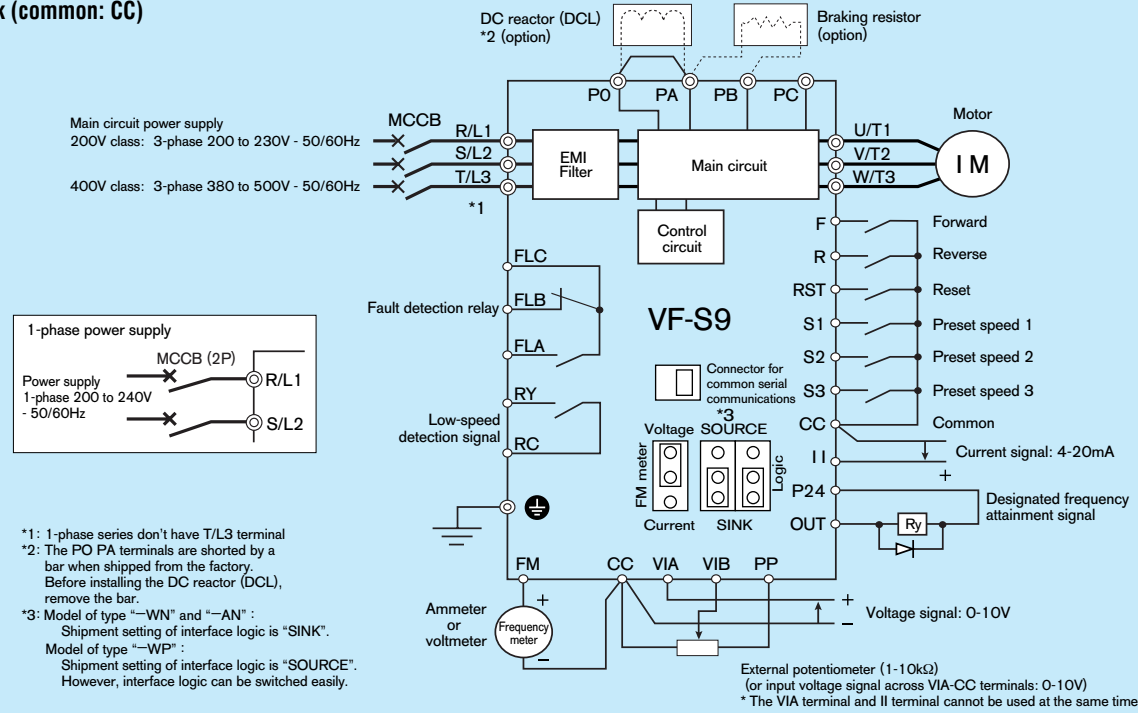

\*1: 1-phase series don't have T/L3 terminal  
 \*2: The PO PA terminals are shorted by a bar when shipped from the factory. Before installing the DC reactor (DCL), remove the bar.  
 \*3: Model of type "--WN" and "--AN": Shipment setting of interface logic is "SINK". Model of type "--WP": Shipment setting of interface logic is "SOURCE". However, interface logic can be switched easily.

## Selection of wiring devices

Voltage class	Capacity applicable motor (kW)	Inverter model	Molded-case circuit breaker (MCCB)		Magnetic contactor (MC)		Overload relay (Th-Ry)		Earth leakage breaker		Wire size (mm <sup>2</sup> )			
			Rated current (A)	Type Note 1)	Rated current (A)	Type Note 1)	Adjusted current (A) (For reference)	Type Note 1)	Rated current (A)	Type Note 1)	Main circuit (mm <sup>2</sup> ) Note 4)	DC reactor (optional) (mm <sup>2</sup> )	Braking resistor/Braking unit (optional) (mm <sup>2</sup> )	Grounding cable (mm <sup>2</sup> ) Note 6)
1-phase 200V class	0.2	VFS9S-2002PL	10	NJ30N	11	C11J	1.3	T13J	10	NJV50E	2.0	1.25	1.25	3.5
	0.4	VFS9S-2004PL	15	NJ30N	11	C11J	2.3	T13J	15	NJV50E	2.0	1.25	1.25	3.5
	0.75	VFS9S-2007PL	20	NJ30N	11	C11J	3.6	T13J	20	NJV50E	2.0	2.0	1.25	3.5
	1.5	VFS9S-2015PL	30	NJ30N	18	C20J	6.8	T13J	30	NJV50E	3.5	2.0	1.25	3.5
	2.2	VFS9S-2022PL	40	NJ50E	35	C35J	9.3	T13J	40	NJV50E	5.5	2.0	2.0	5.5
3-phase 200V class	0.2	VFS9-2002PM	5	NJ30N	11	C11J	1.3	T13J	5	NJV50E	2.0	1.25	1.25	3.5
	0.4	VFS9-2004PM	5	NJ30N	11	C11J	2.3	T13J	5	NJV50E	2.0	1.25	1.25	3.5
	0.75	VFS9-2007PM	10	NJ30N	11	C11J	3.6	T13J	10	NJV50E	2.0	2.0	1.25	3.5
	1.5	VFS9-2015PM	15	NJ30N	11	C11J	6.8	T13J	15	NJV50E	2.0	2.0	1.25	3.5
	2.2	VFS9-2022PM	20	NJ30N	13	C13J	9.3	T13J	20	NJV50E	2.0	2.0	2.0	3.5
	3.7	VFS9-2037PM	30	NJ30N	26	C25J	15	T20J	30	NJV50E	3.5	5.5	5.5	3.5
	5.5	VFS9-2055PL	50	NJ50E	35	C35J	22	T35J	50	NJV50E	8.0	5.5	5.5	8.0
	7.5	VFS9-2075PL	60	NJ100F	50	C50J	28	T35J	60	NJV60F	14	14	5.5	14
	11	VFS9-2110PM	100	NJ100F	65	C65J	44	T65J	100	NJV100F	14	14	5.5	14
3-phase 400V class	0.75	VFS9-4007PL	5	NJ30N	9	C11J	1.6	T13J	5	NJV50E	2.0	1.25	1.25	3.5
	1.5	VFS9-4015PL	10	NJ30N	9	C11J	3.6	T13J	10	NJV50E	2.0	1.25	1.25	3.5
	2.2	VFS9-4022PL	15	NJ30N	9	C11J	5.0	T13J	15	NJV50E	2.0	2.0	1.25	3.5
	3.7	VFS9-4037PL	20	NJ30N	13	C13J	6.8	T13J	20	NJV50E	2.0	2.0	1.25	3.5
	5.5	VFS9-4055PL	30	NJ30N	17	C20J	11	T13J	30	NJV50E	3.5	2.0	2.0	3.5
	7.5	VFS9-4075PL	30	NJ30N	25	C25J	15	T20J	30	NJV50E	3.5	3.5	2.0	3.5
	11	VFS9-4110PL	50	NJ50E	33	C35J	22	T35J	50	NJV50E	5.5	5.5	3.5	5.5
15	VFS9-4150PL	60	NJ100F	48	C50J	28	T35J	60	NJV100F	8.0	8.0	3.5	8.0	

Note) 1. Produced by Schneider Toshiba electric corporation.  
 2. Be sure to attach surge killer to the exciting coil of the relay and the magnetic contactor.  
 Selection of surge killers for Toshiba magnetic contactors  
 200V class: Surge absorbing units are optionally available for Toshiba C11J to C65J, or Model SS-2 for C50J and C65J  
 400V class: For the operation and control circuit, regulate the voltage at 200V or less with a step-down transformer.

Note) 3. When using the auxiliary contacts 2a of the magnetic contactor MC for the control circuit, connect the contacts 2a in parallel to increase reliability.  
 4. Size of the wires connected to the input terminals R, S and T and the output terminals U, V and W when the length of each wire does not exceed 30m.  
 5. For the control circuit, use shielded wires 0.75 mm<sup>2</sup> or more in diameter.  
 6. For grounding, use a cable with a size equal to or larger than the above.

## Main circuit terminal functions

Terminals symbol	Terminal function
	Grounding terminal for connecting inverter case. 2 grounding terminals.
R/L1, S/L2, T/L3	200V class: 1-phase 200 to 240V - 50/60Hz 3-phase 200 to 230V - 50/60Hz 400V class: 3-phase 380 to 500V - 50/60Hz * 1-phase series have R/L1 and S/L2 terminal.
U/T1, V/T2, W/T3	Connect to a (3-phase induction) motor.
PA, PB	Connect to braking resistors. Change parameters <i>F304</i> , <i>F305</i> and <i>F308</i> if necessary.
PC	This is a negative potential terminal in the internal DC main circuit. DC common power can be input across the PA terminals (positive potential).
PO, PA	Terminals for connecting a DC reactor (DCL: optional external device). Shorted when shipped from the factory. Before installing DCL, remove the short bar.

## Control circuit terminal functions

Terminal symbol	Function	Electrical specifications	Wire size
F	Multifunction programmable contact input	Dry contact input 24Vdc - 5mA or less  * Sink/source switchable	Solid wire : 0.3 to 1.5 (mm <sup>2</sup> ) Stranded wire : 0.3 to 1.25 (mm <sup>2</sup> ) (AWG22 to 16) Sheath strip length : 5 (mm)
R			
RST			
S1			
S2			
S3	Shorting across S3-CC causes preset speed operation.		
CC	Control circuit's equipotential terminal (sink logic). 2 common terminals for input/output.		
PP	Power output for analog input setting.	10Vdc (permissible load current: 10mA)	
I1 *	Multifunction programmable analog input. Standard default setting: 4 (0) to 20mAdc input and 0-50Hz (50Hz setting) or 0-60Hz (60Hz setting) frequency.	4 to 20mA (internal impedance: 400Ω)	
VIA *	Multifunction programmable analog input. Standard default setting: 0-10Vdc input and 0-80Hz frequency.	10Vdc (internal impedance: 30kΩ)	
VIB	Multifunction programmable analog input. Standard default setting: 0-10Vdc input and 0-50Hz (50Hz setting) or 0-60Hz (60Hz setting) frequency.	10Vdc (internal impedance: 30kΩ)	
FM	Multifunction programmable analog output. Standard default setting: output current. Connect a 1mA full-scale ammeter or 7.5Vdc (10Vdc)-1mA full-scale voltmeter. Can change to 0-20mA (4-20mA) by jumper switching.	1mA full-scale DC ammeter or 7.5Vdc 1mA full-scale DC voltmeter *Switchable for jumper 0 to 20mA (4 to 20mA) DC ammeter	
P24	24Vdc power output/common at source logic.	24Vdc - 100mA	
OUT	Multifunction programmable open collector output. Standard default settings detect and output speed reach signal output frequencies.	Open collector output: 24Vdc - 50mA  *Sink-source selectable	
RC RY	Multifunction programmable relay contact output. Contact ratings: 250Vac - 2A (cosφ = 1), 30Vdc - 1A, 250Vac - 1A (cosφ = 0.4). Standard default settings detect and output low-speed signal output frequencies.	250Vac - 2A: at resistance load 30Vdc - 1A, 250Vac - 1A (cosφ = 0.4)	Solid wire : 0.3 to 1.5 (mm <sup>2</sup> ) Stranded wire : 0.3 to 1.5 (mm <sup>2</sup> ) (AWG22 to 16) Sheath strip length : 6 (mm)
FLA FLB FLC	Multifunction programmable relay contact output. Contact ratings: 250Vac-2A (cosφ = 1), 30Vdc-1A, 250Vac-1A (cosφ = 0.4). Detects the operation of the inverter's protection function. Contact across FLA-FLC is closed and FLB-FLC is opened during protection function operation.	250Vac - 2A: at resistance load 30Vdc - 1A, 250Vac - 1A (cosφ = 0.4)	

\* The VIA terminal and I1 terminal cannot be used at the same time.

# Inverter Q & A

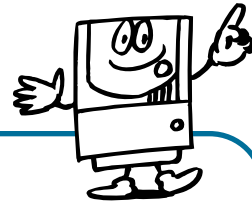

## Q1 How can I use the inverter immediately?

**A1** Just connect the power supply and the motor, and you can use the VF-S9 series inverter immediately.

You can use the RUN and STOP keys and the frequency setting potentiometer to easily operate the inverter. You can also make adjustments easily using the automatic setting functions.

- **Automatic acceleration/deceleration:** Automatically adjusts the acceleration or deceleration time according to the load.
- **Automatic torque increase:** Automatically improves the motor torque according to the load.
- **Automatic environment setting:** Automatically makes all the settings related to the inverter environment protection at one time.
- **Automatic function setting:** Selects the inverter operation method.

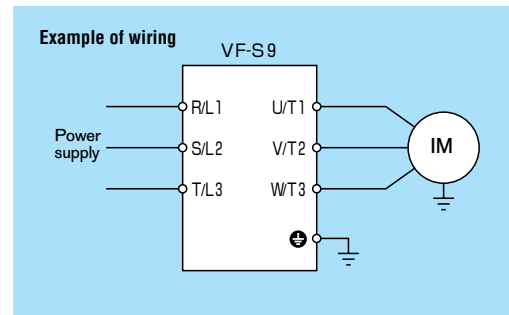

## Q2 What can I do if I forget what I have programmed?

**A2** You can use the change setting retrieval function. You can also use the following operation to restore all the parameters to the default values immediately.

- 1) Change setting retrieval (**Gr-U**): Automatically retrieves and displays only the parameters differing from the default setting. You can confirm the changed parameters.



- 2) Standard setting mode selection (**Gr-UP**): Restores all the parameters to the default values.

Parameter	Setting
Gr-UP (standard setting mode selection)	3 (default value)

Note) When the default setting is entered, the system enters the setup parameter mode.

## Q3 How can I change the frequency by contact input in combination with a PC (programmable controller)?

**A3** Incorporating a standard 15-step speed function, the VF-S9 series allows you to change the frequency by setting parameters and using contact input.

Multi-step contact input signal samples

○ : ON — : OFF (Speed command other than a preset-speed becomes effective when all contacts are OFF.)

Terminal	Preset-speed														
	1	2	3	4	5	6	7	8	9	10	11	12	13	14	15
S1-CC	○	—	○	—	○	—	○	—	○	—	○	—	○	—	○
S2-CC	—	○	—	○	—	○	—	○	—	○	—	○	—	○	—
S3-CC	—	—	—	○	—	○	—	○	—	○	—	○	—	○	—
RST-CC	—	—	—	—	—	—	—	—	—	○	○	○	○	○	○

You can change the frequency using contact input.

Parameter	Setting
Sr 1 (F280) (Preset-speed operation frequencies 1)	Lower limit frequency-Upper limit frequency
Sr 7 (F286) (Preset-speed operation frequencies 7)	Lower limit frequency-Upper limit frequency
F294 (Preset-speed operation frequencies 15)	Lower limit frequency-Upper limit frequency
F 1 14 (Input terminal Selection 4)	6 (Preset-speed command 1)
F 1 15 (Input terminal Selection 5)	7 (Preset-speed command 2)
F 1 16 (Input terminal Selection 6)	8 (Preset-speed command 3)
F 1 13 (Input terminal Selection 3)	9 (Preset-speed command 4)

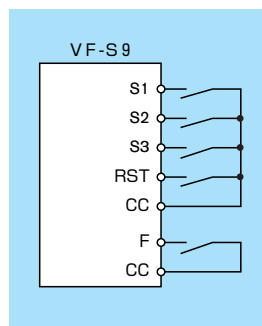

## Q4 What is the input/output programmable terminal block?

**A4** The VF-S9 series allows you to set the terminal functions as you wish from a broad menu selection.

Parameter	Setting
F 1 11 Input terminal selection 1 (F)	2 (Forward run)
F 1 12 Input terminal selection 2 (R)	3 (Reverse run)
F 1 13 Input terminal selection 3 (RST)	10 (Reset)
F 1 14 Input terminal selection 4 (S1)	6 (Preset-speed 1)
F 1 15 Input terminal selection 5 (S2)	7 (Preset-speed 2)
F 1 16 Input terminal selection 6 (S3)	8 (Preset-speed 3)
F 130 Output terminal selection 1 (RY-RC)	4 (Low-speed detection signal)
F 131 Output terminal selection 2 (OUT)	5 (Designated frequency reach)
F 132 Output terminal selection 3 (FL)	10 (Failure FL)

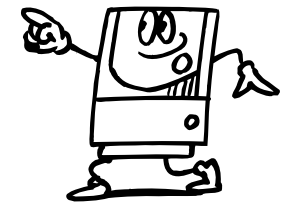

Table of input terminal functions

Function No.	Code	Function
0	—	No function is assigned
1	ST	Standby terminal
2	F	Forward-run command
3	R	Reverse-run command
4	JOG	Jog run command
5	AD2	Acceleration/deceleration 2 pattern selection
6	SS1	Preset-speed command 1
7	SS2	Preset-speed command 2
8	SS3	Preset-speed command 3
9	SS4	Preset-speed command 4
10	RST	Reset command
11	EXT	Trip stop command from external input device
12	PNL/TB	Operation panel/terminal board switching
13	DB	DC braking command
14	PI	Prohibition of PI control
15	PWENE	Permission of parameter editing
16	ST+RST	Combination of standby and reset commands
17	ST+PNL/TB	Combination of standby and operation panel/terminal board switching
18	F+JOG	Combination of forward run and jog run
19	R+JOG	Combination of reverse run and jog run
20	F+AD2	Combination of forward run and acceleration/deceleration 2
21	R+AD2	Combination of reverse run and acceleration/deceleration 2
22	F+SS1	Combination of forward run and preset-speed command 1
23	R+SS1	Combination of reverse run and preset-speed command 1
24	F+SS2	Combination of forward run and preset-speed command 2
25	R+SS2	Combination of reverse run and preset-speed command 2
26	F+SS3	Combination of forward run and preset-speed command 3
27	R+SS3	Combination of reverse run and preset-speed command 3
28	F+SS4	Combination of forward run and preset-speed command 4
29	R+SS4	Combination of reverse run and preset-speed command 4
30	F+SS1+AD2	Combination of forward run, preset-speed command 1 and acceleration/deceleration 2
31	R+SS1+AD2	Combination of reverse run, preset-speed command 1 and acceleration/deceleration 2
32	F+SS2+AD2	Combination of forward run, preset-speed command 2 and acceleration/deceleration 2
33	R+SS2+AD2	Combination of reverse run, preset-speed command 2 and acceleration/deceleration 2
34	F+SS3+AD2	Combination of forward run, preset-speed command 3 and acceleration/deceleration 2
35	R+SS3+AD2	Combination of reverse run, preset-speed command 3 and acceleration/deceleration 2
36	F+SS4+AD2	Combination of forward run, preset-speed command 4 and acceleration/deceleration 2
37	R+SS4+AD2	Combination of reverse run, preset-speed command 4 and acceleration/deceleration 2
38	FCHG	Frequency command forced switching
39	THR2	No. 2 thermal switching
40	MCHG	No. 2 motor switching
41	UP	Frequency UP signal input from external contacts
42	DOWN	Frequency DOWN signal input from external contacts
43	CLR	Frequency UP/DOWN clear signal input from external contacts
44	CLR+RST	Combination of frequency UP/DOWN clear and reset by means of external contacts
45	EXTN	Inversion of trip stop command from external device
46	OH	Thermal trip stop signal input from external device
47	OHN	Inversion of thermal trip stop command from external device
48	SC/LC	Remote/local control forced switching
49	HD	Operation holding (stop of 3-wire operation)

Table of output terminal functions

Function No.	Code	Function
49	HD	Operation holding (stop of 3-wire operation)
50	SDBF	Forward run after DC braking
51	SDBR	Reverse run after DC braking
52	FCR	Forced operation (factory setting needed)
53	FIRES	Fire speed control
0	LL	Frequency lower limit
1	LLN	Inversion of frequency lower limit
2	UL	Frequency upper limit
3	ULN	Inversion of frequency upper limit
4	LOW	Low-speed detection signal
5	LOWN	Inversion of low-speed detection signal
6	RCH	Designated frequency reach signal (completion of acceleration/deceleration)
7	RCHN	Inversion of designated frequency reach signal (inversion of completion of acceleration/deceleration)
8	RCHF	Set frequency reach signal
9	RCHFV	Inversion of set frequency reach signal
10	FL	Failure FL (trip output)
11	FLN	Inversion of failure FL (inversion of trip output)
12	OT	Over-torque detection
13	OTN	Inversion of over-torque detection
14	RUN	RUN/STOP
15	RUNN	Inversion of RUN/STOP
16	POL	OL pre-alarm
17	POLN	Inversion of OL pre-alarm
18	POHR	Braking resistor overload pre-alarm
19	POHRN	Inversion of braking resistor overload pre-alarm
20	POT	Over-torque detection pre-alarm
21	POTN	Inversion of over-torque detection pre-alarm
22	PAL	Pre-alarm
23	PALN	Inversion of pre-alarm
24	UC	Low-current detection
25	UCN	Inversion of low-current detection
26	HFL	Hard fault
27	HFLN	Inversion of hard fault
28	LFL	Soft fault
29	LFLN	Inversion of soft fault
30	RDY1	Ready for operation (including ST, RUN)
31	RDY1N	Inversion of ready for operation (including ST, RUN)
32	RDY2	Ready for operation
33	RDY2N	Inversion of ready for operation
34	FCVIA	Selection of frequency reference for VIA
35	FCVIAN	Selection of frequency reference for VIA (inverted)
36	TB VIA	Selection of terminal for VIA
37	TB VIAN	Selection of terminal for VIA (inverted)
38	OUT0	Communication data output 1
39	OUTON	Communication data output 1 (inverted)
40	OUT1	Communication data output 2
41	OUT1N	Communication data output 2 (inverted)

## Q5 How can I get a large torque?

**A5** The VF-S9 series ensures a torque of 150% or more from low speeds by utilizing Toshiba's sensorless vector control.

Enable the sensorless vector control for a load that requires high starting or low speed torque.

To use sensorless vector control

- 1) When automatic torque increase  $F1U2 = 1$  is set, all the sensorless vector controls and motor constants are set at one time.
- 2) Set V/F control mode selection  $F1E = 3$  (sensorless vector control). Set the motor constant.
  - (1) For the same capacity as the inverter with the 4P Toshiba standard motor, it is not necessary to set the motor constants.

(2) The motor constants can be automatically set using the auto-tuning function  $F400 = 2$  (Auto tuning).

(3) The motor constants can be set individually.

- F401 : Slip frequency
- F402 : Motor primary constant
- F403 : Motor secondary constant
- F404 : Motor excitation constant
- F405 : Magnification of load inertial moment
- F408 : Rated capacity ratio of motor to inverter

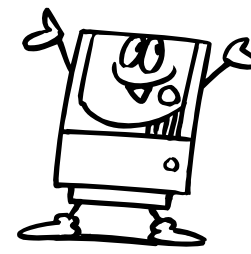

## Q6 How do I start/stop a motor by external contacts, and control the frequency by a current signal of 4-20 mA (or a voltage signal of 0-10 Vdc.)

**A6** To allow start/stop of the motor by external contacts, and to control the frequency by a current (voltage) signal, you need to set the following parameters:

### Parameters to be changed

Parameter	Setting
<b>CMDd</b> (Command mode selection)	0 (Terminal board)
<b>FMDd</b> (Frequency setting mode selection)	0 (Terminal board)

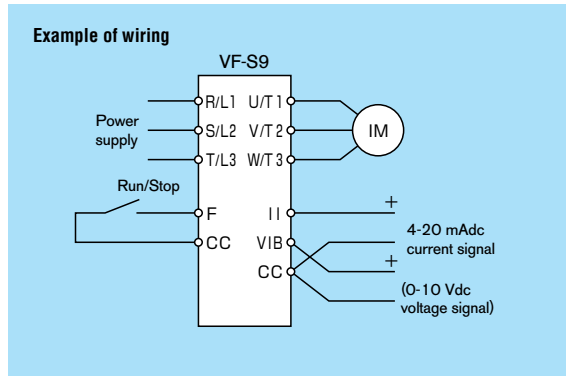

Note) Because they are connected to each other in the inverter, the VIA and II terminals cannot be used jointly. Use terminal VIB for joint use with terminal II.

### CMDd (Command mode selection) is a parameter to determine the source of the operation signal.

For performing run/stop through a terminal → set to 0 (terminal board).  
For performing run/stop with RUN/STOP key on the panel → set to 1 (panel).

### FMDd (Frequency setting mode selection) is a parameter to determine the place for providing frequency command.

For providing frequency by current (voltage) signal through a terminal → set to 0 (terminal board).  
For setting with UP/DOWN key on the panel → To be set on 1 (operation panel).  
For setting with potentiometer → To be set to 2 (internal potentiometer).

## Q7 Why do other devices malfunction due to noise?

**A7** Using PWM control, the VF-S9 series generates noise that may affect nearby instrumentation and electronic equipment.

Noise is classified by propagation route into transmission noise, and radiation noise. Take the following counter measures for noise which affects other equipment:

- Separate the signal cables from the power cables with sufficient distance.
- Install noise filters.
- \*VF-S9 series have a built-in noise filter (primary of inverter).
- Use twisted-pair shielding cables for weak electric circuits and signal circuits, and be sure to ground one end of the shielding.
- Install the inverters separately from other equipment.
- Cover the inverters and their cables with metal conduit tubes and metal control panels, and ground these covers.
- EMC plate is attached for measures of radiation noise.

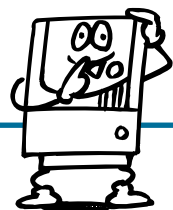
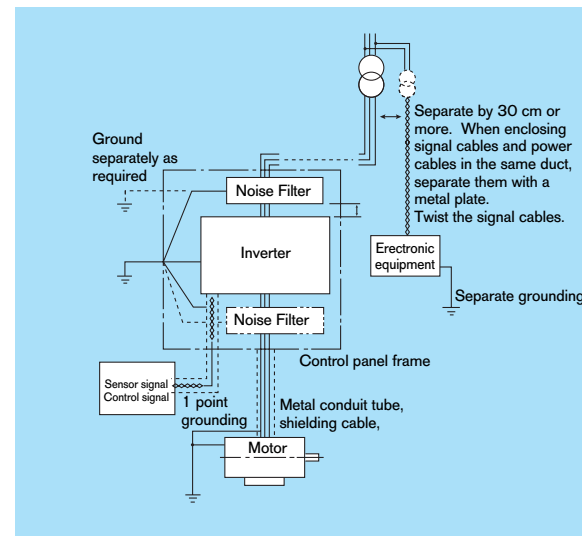

## When wiring the inverter

### Wiring precautions

#### Installing a molded-case circuit breaker [MCCB]

- (1) Install a molded-case circuit breaker (MCCB) on the inverter's power supply input to protect the wiring.
- (2) Avoid turning the molded-case circuit breaker on and off frequently to turn on/off the motor.
- (3) To turn on/off the motor frequently, close/break the control terminals F (or R)-CC.

#### Installing a magnetic contactor [MC] [primary side]

- (1) To prevent an automatic restart after the power interruption or overload relay has tripped, or actuation of the protective circuit, install an electro-magnetic contact in the power supply.
- (2) Because the VF-S9 inverter has a built-in fault detection relay [FL], the primary end magnetic contactor (MC) can be configured to trip on activation of the inverter's protective functions by connecting the contact points of the FL to the operation circuit of the MC.
- (3) The inverter can be used without a magnetic contactor. In this case, use an MCCB (equipped with a voltage tripping device) for opening the primary circuit when the inverter protective circuit is activated.
- (4) Avoid turning the magnetic contactor on and off frequently to turn on/off the motor.
- (5) To turn on/off the motor frequently, close/break the control terminals F (or R)-CC.
- (6) Install a surge suppressor on the excitation coil of the magnetic contactor (MC).

#### Installing a magnetic contactor [MC] [secondary side]

- (1) As a rule, if a magnetic contactor is installed between the inverter and the motor, do not turn of ON/OFF while running. (If the secondary-side contactor is turned of ON/OFF while running, a large current may flow in the inverter, causing inverter damage and failure.)
- (2) A magnetic contactor may be installed to change the motor or change to the commercial power source when the inverter is stopped. Always use an interlock with the magnetic contactor in this situation so that the commercial power supply is not applied to the inverter's output terminals.

#### External signal

- (1) Use a relay rated for low currents. Mount a surge suppressor on the excitation coil of the relay.
- (2) When wiring the control circuit, use shielded wires or twisted pair cables.
- (3) Because all of the control terminals except FLA, FLB and FLC are connected to electronic circuits, insulate these terminals to prevent them from coming into contact with the main circuit.

#### Installing an overload relay

- (1) The VF-S9 inverter has a built-in overload protection function by means of a thermal relay. However, in the following cases, the thermal relay operation level must be adjusted or an overload relay matching the motor's characteristics must be installed between the inverter and the motor.
  - (a) When using a motor having a rated current value different from that of the equivalent.
  - (b) When driving several motors simultaneously.
- (2) When you want to use a constant-torque Toshiba VF motor together with the VF-S9 inverter, change the inverter's electronic thermal protection characteristics to match those of the VF motor.
- (3) In order to adequately protect a motor used for low-speed operation, we recommend the use of a motor equipped with an embedded thermal relay.

## When changing the motor speed

### Application to standard motors

#### Vibration

When a motor is operated with an industrial inverter, it experiences more vibrations than when it is operated by the commercial power supply. The vibration can be reduced to a negligible level by securing the motor and machine to the base firmly. If the base is weak, however, the vibration may increase at a light load due to resonance with the mechanical system.

#### Reduction gear, belt, chain

Note that the lubrication capability of a reducer or a converter used as the interface of the motor and the load machine may be affected at low speeds. When operating at a frequencies exceeding 60 Hz or higher, power transmission mechanisms such as reduction gear, belts and chains, may cause problems such as production of noise, a reduction in strength, or shortening of service life.

#### Frequency

Before setting the maximum frequency to 60 Hz or higher, confirm that this operating range is acceptable for the motor.

### Application to special motors

#### Braking motor

When using a braking motor, if the braking circuit is directly connected to the inverters's output terminals, the brake cannot be released because of the lowered starting voltage. Therefore, when using a braking motor, connect the braking circuit to the inverter's power supply side, as shown in the figure below. Usually, braking motors produce larger noise in low speed ranges.

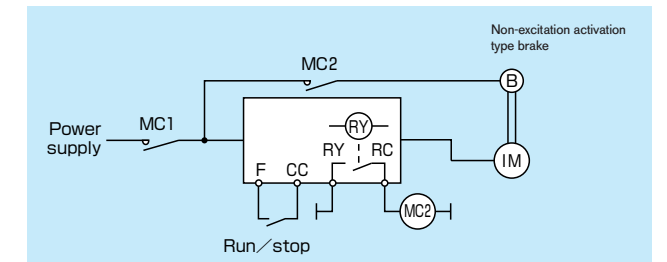

#### Gear motor

When using an industrial inverter to drive a gear motor, inquire of the motor manufacturer about its continuous operation range, since low-speed operation of a gear motor may cause insufficient lubrication.

#### Toshiba Gold Motor (High-efficiency power-saving motor)

Inverter-driven operation of Toshiba Gold Motors is the best solution for saving energy. This is because these motors have improved efficiency, power factor, and noise/vibration reduction characteristics when compared to standard motors.

#### Pole-changing motor

Pole-changing motors can be driven by the VF-S9 inverter. Before changing poles, however, be sure to let the motor come to a complete stop.

#### High-pole-count motors

Note that high-pole count motors (8 or more poles), which may be used for fans, etc., have higher rated current than 4-pole motors. The current ratings of multipole motors are relatively high. So, when selecting an inverter, you must pay special attention to its current rating so that the current rating of the motor is below that of the inverter.

#### Single-phase motor

Because single-phase motors are equipped with a centrifugal switch and capacitors for starting, they cannot be driven by an inverter. If only a single-phase power system is available a 3-phase motor can be driven by using a single-phase input inverter to convert it into a 3-phase 200V output. (A special inverter and a 3-phase motor are required.)

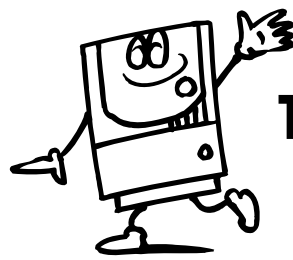

# To users of our inverters

## When studying how to use our inverters

### Notes

#### Leakage current

The VF-S9 series of inverters uses high-speed switching devices for PWM control. When a relatively long cable is used for power supply to an inverter, current may leak from the cable or the motor to the ground because of its capacitance, adversely affecting peripheral equipment. The intensity of such a leakage current depends on the PWM carrier frequency, the lengths of the input and output cables, etc., of the inverter. To prevent current leakage, it is recommended to take the following measures.

#### [Effects of leakage current]

Leakage current which increases when an inverter is used may pass through the following routes:

- Route (1) ... Leakage due to the capacitance between the ground and the noise filter
- Route (2) ... Leakage due to the capacitance between the ground and the inverter
- Route (3) ... Leakage due to the capacitance between ground and the cable connecting the inverter and the motor
- Route (4) ... Leakage due to the capacitance of the cable connecting the motor and an inverter in another power distribution line
- Route (5) ... Leakage through the grounding line common to motors
- Route (6) ... Leakage to another line because of the capacitance of the ground

Leakage current which passes through the above routes may cause the following trouble.

- Malfunction of a leakage circuit breaker in the same or another power distribution line
- Malfunction of a ground-relay installed in the same or another power distribution line
- Noise produced at the output of an electronic device in another power distribution line
- Activation of an external thermal relay installed between the inverter and the motor, at a current below the rated current

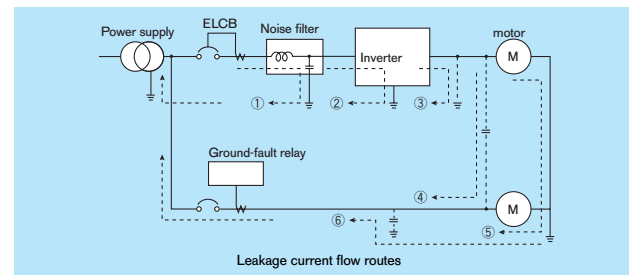

#### [Measures against effects of leakage current]

The measures against the effects of leakage current are as follows:

- 1) Measures to prevent the malfunction of leakage circuit breakers
  - (1) Decrease the PWM carrier frequency of the inverter. In the case of the VF-S9, the frequency can be decreased to 2.0kHz. (\*)
  - (2) Install leakage circuit breakers (ELCB) with a high-frequency protective function (e.g., Toshiba Mighty series of breakers) in both the same and the other power distribution lines. This makes it possible to operate the VF-S9 with its PWM carrier frequency set high.
- 2) Measures against malfunction of ground-fault relay:
  - (1) Decrease the PWM carrier frequency of the inverter. In the case of the VF-S9, the frequency can be decreased to 2.0kHz. (\*)
  - (2) Install ground-fault relays with a high-frequency protective function (e.g., Toshiba CCR12 type of relays) in both the same and other lines. This makes it possible to operate the VF-S9 with its PWM carrier frequency set high.
- 3) Measures against noise produced by other electric and electronic systems:
  - (1) Separate the grounding line of the inverter from that of the affected electric and electronic systems.
  - (2) Decrease the PWM carrier frequency of the inverter. In the case of the VF-S9, the frequency can be decreased to 2.0kHz. (\*)
- 4) Measures against malfunction of external thermal relays:
  - (1) Remove the external thermal relay and use the electronic thermal function of the inverter instead of it. (Unapplicable to cases where a single inverter is used to drive more than one motor. Refer to the instruction manual for measures to be taken when thermal relays cannot be removed.)
  - (2) Decrease the PWM carrier frequency of the inverter. In the case of the VF-S9, the frequency can be decreased to 2.0kHz.

(Note) If the carrier frequency reduce, the magnetic noise caused by the motor increase.

5) Measures by means of wiring and grounding

- (1) Use a grounding wire as large as possible.
  - (2) Separate the inverter's grounding wire from that of other systems or install the grounding wire of each system separately to the grounding point.
  - (3) Ground (shield) the main circuit wires with metallic conduits.
- (\*) : The PWM carrier frequency should not be decreased below 2.2kHz in the vector control mode.

#### Ground fault

Before beginning operation, thoroughly check the wiring between the motor and the inverter for incorrect wiring or short circuits. Do not ground the neutral point of any star-connected motor.

#### Radio interference

[Noise produced by inverters]

Since the VF-S9 series of inverters performs PWM control, it produces noise and sometimes affects nearby instrumental devices, electrical and electronic systems, etc. The effects of noise greatly vary with the noise resistance of each individual device, its wiring condition, the distance between it and the inverter, etc.

#### [Measures against noises]

According to the route through which noise is transmitted, the noises produced by an inverter are classified into transmission noise, induction noise and radiation noise.

#### [Examples of protective measures]

- Separate the power line from other lines, such as weak-current lines and signal lines, and install them apart from each other.
- Install a noise filter in each inverter. It is effective for noise prevention to install noise filters in other devices and systems, as well.
- Shield cables and wires with grounded metallic conduits, and cover electronic systems with grounded metallic cases.
- Separate the power distribution line of the inverter from that of other devices and systems.
- Install the input and output cables of the inverter apart from each other.
- Use shielded twisted pair wires for wiring of the weak-current and signal circuits, and always ground one of each pair of wires.
- Ground the inverter with grounding wires as large and short as possible, separately from other devices and systems.

All models have built-in noise filters which significantly reduce noise.

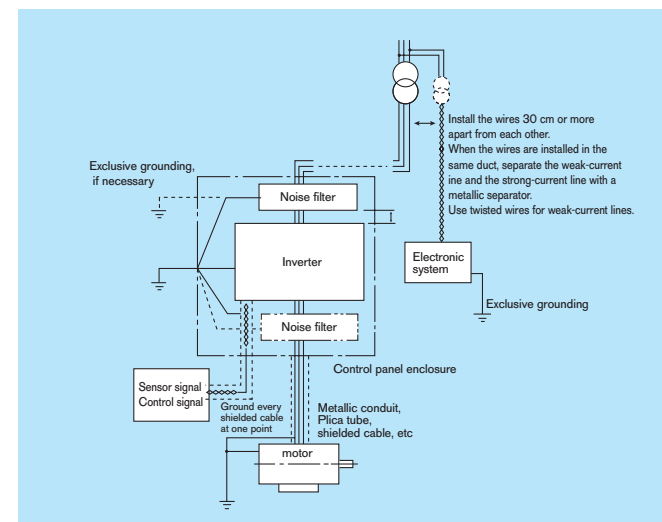

#### Power factor improvement capacitors

Do not install a power factor improvement capacitors on the input or output side of the inverter.

Installing a power factor improvement capacitor on the input or output side causes current containing harmonic components to flow into the capacitor, adversely affecting the capacitor itself or causing the inverter to trip. To improve the power factor, install an input AC reactor or a DC reactor (optional) on the primary side of the inverter.

#### Installation of input AC reactors

These devices are used to improve the input power factor and suppress high harmonic currents and surges. Install an input AC reactor when using a VF-S9 inverter under the following conditions:

- (1) When the power source capacity is 200kVA or more, and when it is 10 times or more greater than the inverter capacity.
- (2) When the inverter is connected the same power distribution system as a thyristor-committed control equipment.
- (3) When the inverter is connected to the same power distribution system as that of distorted wave-producing systems, such as arc furnaces and large-capacity inverters.

#### Standard replacement intervals of main parts

The table below lists standard component replacement intervals under normal operating conditions (i.e., average year round ambient temperature of 30°C, load ratio of 80% or less, average operation time of 12 hours/day). The replacement intervals do not indicate the service life of each component, but the number of years beyond which the failure rate of a component used without being replaced increases sharply because of deterioration and wear.

Component name	Standard replacement intervals	Replacement method, etc.
Cooling fan	2 to 3 years	Replaced with a new one
Smoothing capacitor	5 years	Replaced with a new one (upon examination)
Circuit breaker, relay	—	Decided upon examination
Timer	—	Decided upon examination of the cumulative operation time
Fuse	10 years	Replaced with a new one
Aluminum capacitors on the printed circuit board	5 years	Replaced with a new circuit board (upon examination)

Extract from "Periodic Inspection of General-purpose Inverters" published by the Japan Electrical Manufacturers' Association

Note: The service life of each component greatly varies with its usage environment.

## Selecting the capacity (model) of the inverter

### Selection

#### Capacity

Refer to the applicable motor capacities listed in the standard specifications.

When driving a high-pole motor, special motor, or multiple motors in parallel, select such an inverter that the sum of the motor rated current multiplied by 1.05 to 1.1 is less than the inverter's rated output current value.

#### Acceleration/deceleration times

The actual acceleration and deceleration times of a motor driven by an inverter are determined by the torque and moment of inertia<sup>2</sup> of the load, and can be calculated by the following equations.

The acceleration and deceleration times of an inverter can be set individually. In any case, however, they should be set longer than their respective values determined by the following equations.

Acceleration time	$t_a = \frac{(J_u + J_L) \times \Delta N}{9.56 \times (T_u - T_L)} \text{ (sec.)}$
Deceleration time	$t_b = \frac{(J_u + J_L) \times \Delta N}{9.56 \times (T_u + T_L)} \text{ (sec.)}$
Conditions	$J_u$ : Moment of inertia of motor (kge.m <sup>2</sup> ) $J_L$ : Moment of inertia of load (kge.m <sup>2</sup> ) (converted into value on motor shaft) $\Delta N$ : Difference in rotating speed between before and after acc. or dec. (min. <sup>-1</sup> ) $T_u$ : Load torque (Ne.m) $T_u$ : Motor rated torque x 1.2-1.3 (Ne.m) ... V/f control $T_u$ : Motor rated torque x 1.5 (Ne.m) ... Vector operation control $T_b$ : Motor rated torque x 0.2 (Ne.m) (When a braking resistor or a braking resistor unit is used: ) $T_b$ : Motor rated torque x 0.8-1.0 (Ne.m)

#### Allowable torque characteristics

When a standard motor is combined with an inverter to perform variable speed operation, the motor temperature rises slightly higher than it normally does during commercial power supply operation. This is because the inverter output voltage has a sinusoidal (approximate) PWM waveform. In addition, the cooling becomes less effective at low speed, so the torque must be reduced according to the frequency. When constant-torque operation must be performed at low speeds, use a Toshiba VF motor designed specifically for use with inverters.

#### Starting characteristics

When a motor is driven by an inverter, its operation is restricted by the inverter's overload current rating, so the starting characteristic is different from those obtained from commercial power supply operation.

Although the starting torque is smaller with an inverter than with the commercial power supply, a high starting torque can be produced at low speeds by adjusting the V/f pattern torque boost amount or by employing vector control. (200% in sensorless control mode, though this rate varies with the motor characteristics.) When a larger starting torque is necessary, select an inverter with a larger capacity and examine the possibility of increasing the motor capacity.

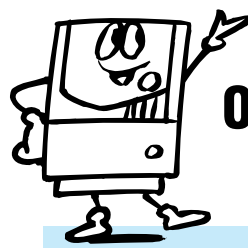

# Optional external devices

The following external devices are optionally available for the VF-S9 series of inverters.

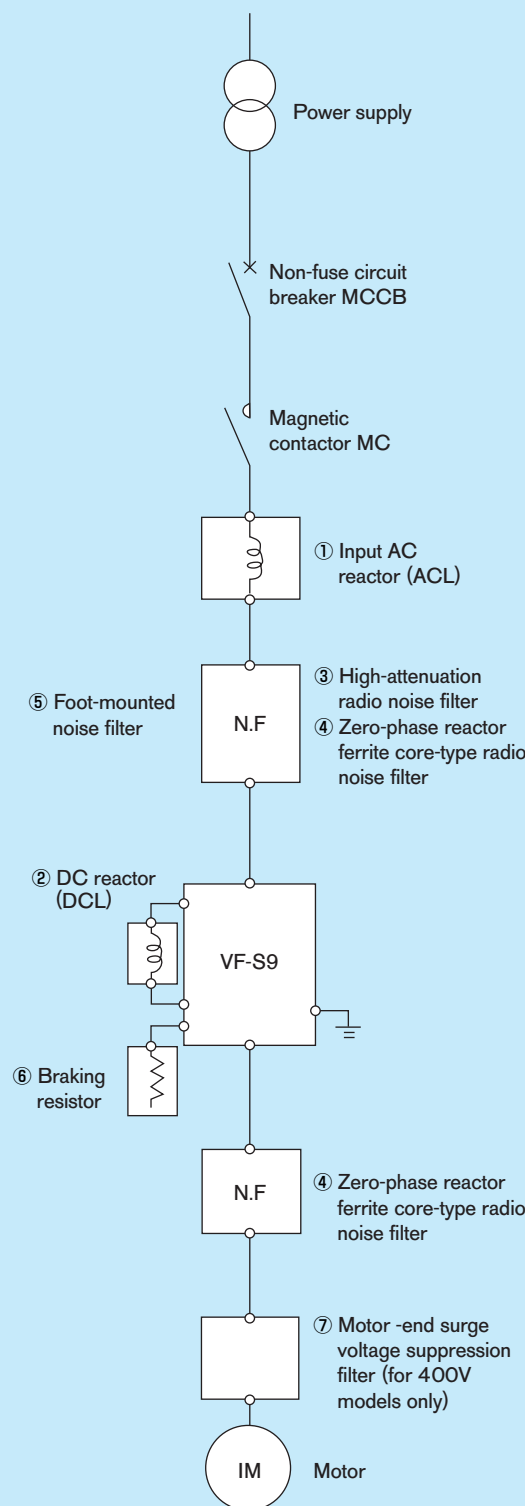

No.	Device	Function, Purpose, etc.	Refer to
①	Input AC reactor	Used to improve the input power factor, reduce the harmonics, and suppress external surge on the inverter power source side. Install when the power capacity is 500 kVA or more and 10 times or more than the inverter capacity or when a distorted wave generation source such as a thyristor unit or a large-capacity inverter is connected in the same distribution system.	P. 18
②	DC reactor	Improves the power factor more than the input reactor. When the facility applying the inverter requires high reliability, it is recommended to use the DC reactor with an input reactor effective for external surge suppression. * An inverter unit of 200V-3.7kW or less is connected to a reactor selected on P. 18 to conform "Guides of limits for harmonics current emissions on general purpose inverter having an input current up to and including 20A per phase" by the Japan Electrical Manufacturers' Association.	P. 18
③	High-attenuation filter (LC filter) NF type manufactured by Soshin Electric Co.	These types of filters are not necessary because all single-phase 200 V or 3-phase 400 V models and 3-phase 200 V, 5.5 kW or 7.5 kW models have a built-in EMI noise filter, conforming to Class A, as standard. But install these filters if necessary of noise reduction more and more. • Effective to prevent interference with audio equipment used near the inverter. • Install on the input side of the inverter. • Provided with wide-range attenuation characteristics from AM radio bands to near 10 MHz. • Use when equipment readily affected by noise is installed in the peripheral area.	P. 19
④	Zero-phase reactor (inductive filter) Ferrite core type manufactured by Soshin Electric Co.	• Effective to prevent interference with audio equipment used near the inverter. • Effective in noise reduction on both input and output sides of the inverter. • Provided with attenuation characteristics of several dB in frequencies from AM radio bands to 10 MHz. • For noise countermeasures, insert on the secondary side of the inverter.	P. 19
⑤	Foot-mounted type noise reduction filter	High-attenuation EMI noise filter requiring only small space; mounted on the rear side of the inverter. This filter can be installed to conform to the following classes of EMC standard EN5501 Group 1. 3-phase 200 V models excluding those of 5.5/7.5 kW : Conform to Class A. All models other than above : Conform to Class B.	P. 19
⑥	Braking resistor	Use when rapid deceleration or stop is frequently required or when it is desired to reduce the deceleration time with large load. This resistor consumes regenerative energy during power generation braking. • Braking resistor -- With (resistor + protective thermal relay) built in.	P. 20
⑦	Motor-end surge voltage suppression filter (400 V class only)	Use an insulation-reinforced motor or install the surge voltage restraint filter to prevent degrading motor insulation caused by surge voltage generation depending on cable length and wiring method, or use of a 400 V class motor driven with an inverter.	Contact your Toshiba representative.
⑧	Conduit pipe kit	Attachment kit used for conformance to NEMA TYPE1.	
⑨	IP43 enclosure kit	Attachment kit for making a panel conform to the IP43 structure.	
⑩	DIN rail kit	Available for the 200 V class models of 0.75 kW or less. (Model: DIN001Z)	
⑪	Parameter writer	Use this unit for batch read, batch copy, and batch writing of setting parameters. (Model: PWU001Z)	P. 20
⑫	Extension panel	Extended operation panel kit provided with LED indication section, RUN/STOP key, UP/DOWN key, Monitor key, and Enter key. (Model: RKPO01Z)	
⑬	RS485 communication converter unit	Use to connect a personal computer for data communication with up to 64 or 256 units. (Model: RS4001Z, RS4002Z)	
⑭	RS232C communication converter unit	Use to connect a personal computer for data communication. (Model: RS2001Z)	
⑮	Remote panel	Provided with built-in frequency indicator, frequency setting device, and RUN-STOP (forward/reverse) switch. (Model: CBVR-7B1)	P. 21
⑯	Application control unit	AP Series is available to enable various types of application control functions when combined with an inverter. Contact your Toshiba representative for further information.	—

Device	External dimensions and connections																																																																																																																																																													
Input AC reactor (ACL)	<p>Fig.A Fig.B</p> <table border="1"> <thead> <tr> <th rowspan="2">Type</th> <th rowspan="2">Rating</th> <th rowspan="2">Inverter type</th> <th colspan="8">Dimensions (mm)</th> <th rowspan="2">Drawing</th> <th rowspan="2">Terminals</th> <th rowspan="2">Approx. weight. (kg)</th> </tr> <tr> <th>A</th> <th>B</th> <th>C</th> <th>D</th> <th>E</th> <th>F</th> <th>G</th> </tr> </thead> <tbody> <tr> <td>PFLS2002S</td> <td>1φ-230V-2.0A-50/60Hz</td> <td>VFS9S-2002PL</td> <td>80</td> <td>55</td> <td>115</td> <td>63</td> <td>45</td> <td>5</td> <td>45</td> <td rowspan="3">A</td> <td>M3.5</td> <td>0.85</td> </tr> <tr> <td>PFL2001S</td> <td>3φ-230V-1.7A-50/60Hz</td> <td>VFS9-2002PM</td> <td>105</td> <td>65</td> <td>115</td> <td>90</td> <td>55</td> <td>5</td> <td>40</td> <td>M3.5</td> <td>1.0</td> </tr> <tr> <td>PFL2005S</td> <td>3φ-230V-5.5A-50/60Hz</td> <td>VFS9-2004PM, 2007PM VFS9S-2004PL, 2007PL</td> <td>105</td> <td>65</td> <td>115</td> <td>90</td> <td>55</td> <td>5</td> <td>40</td> <td>M3.5</td> <td>1.2</td> </tr> <tr> <td>PFL2011S</td> <td>3φ-230V-11A-50/60Hz</td> <td>VFS9-2015PM, 2022PM</td> <td>130</td> <td>70</td> <td>140</td> <td>115</td> <td>60</td> <td>5</td> <td>50</td> <td rowspan="2">B</td> <td>M4</td> <td>2.3</td> </tr> <tr> <td>PFL2018S</td> <td>3φ-230V-18A-50/60Hz</td> <td>VFS9-2037PM, VFS9S-2015PL, VFS9S-2022PL</td> <td>130</td> <td>70</td> <td>140</td> <td>115</td> <td>60</td> <td>5</td> <td>50</td> <td>M4</td> <td>2.5</td> </tr> <tr> <td>PFL2025S</td> <td>3φ-230V-25A-50/60Hz</td> <td>VFS9-2055PL</td> <td>125</td> <td>100</td> <td>130</td> <td>50</td> <td>83</td> <td>7</td> <td>—</td> <td rowspan="3">B</td> <td>M4</td> <td>2.6</td> </tr> <tr> <td>PFL2050S</td> <td>3φ-230V-50A-50/60Hz</td> <td>VFS9-2075PL, VFS9-2110PM</td> <td>155</td> <td>115</td> <td>140</td> <td>50</td> <td>95</td> <td>7</td> <td>—</td> <td>M6</td> <td>3.4</td> </tr> <tr> <td>PFL2100S</td> <td>3φ-230V-100A-50/60Hz</td> <td>VFS9-2150PM</td> <td>230</td> <td>150</td> <td>210</td> <td>60</td> <td>90</td> <td>8</td> <td>—</td> <td>M8</td> <td>8.2</td> </tr> <tr> <td>PFL4012S</td> <td>3φ-460V-12.5A-50/60Hz</td> <td>VFS9-4007PL~VFS9-4037PL</td> <td>125</td> <td>95</td> <td>130</td> <td>50</td> <td>79</td> <td>7</td> <td>—</td> <td rowspan="3">B</td> <td>M4</td> <td>2.3</td> </tr> <tr> <td>PFL4025S</td> <td>3φ-460V-25A-50/60Hz</td> <td>VFS9-4055PL~VFS9-4110PL</td> <td>155</td> <td>110</td> <td>155</td> <td>50</td> <td>94</td> <td>7</td> <td>—</td> <td>M4</td> <td>4.9</td> </tr> <tr> <td>PFL4050S</td> <td>3φ-460V-50A-50/60Hz</td> <td>VFS9-4150PL</td> <td>155</td> <td>140</td> <td>165</td> <td>50</td> <td>112</td> <td>7</td> <td>—</td> <td>M6</td> <td>6.6</td> </tr> </tbody> </table> <p>Note) PFL2002S has 4 terminals.</p>	Type	Rating	Inverter type	Dimensions (mm)								Drawing	Terminals	Approx. weight. (kg)	A	B	C	D	E	F	G	PFLS2002S	1φ-230V-2.0A-50/60Hz	VFS9S-2002PL	80	55	115	63	45	5	45	A	M3.5	0.85	PFL2001S	3φ-230V-1.7A-50/60Hz	VFS9-2002PM	105	65	115	90	55	5	40	M3.5	1.0	PFL2005S	3φ-230V-5.5A-50/60Hz	VFS9-2004PM, 2007PM VFS9S-2004PL, 2007PL	105	65	115	90	55	5	40	M3.5	1.2	PFL2011S	3φ-230V-11A-50/60Hz	VFS9-2015PM, 2022PM	130	70	140	115	60	5	50	B	M4	2.3	PFL2018S	3φ-230V-18A-50/60Hz	VFS9-2037PM, VFS9S-2015PL, VFS9S-2022PL	130	70	140	115	60	5	50	M4	2.5	PFL2025S	3φ-230V-25A-50/60Hz	VFS9-2055PL	125	100	130	50	83	7	—	B	M4	2.6	PFL2050S	3φ-230V-50A-50/60Hz	VFS9-2075PL, VFS9-2110PM	155	115	140	50	95	7	—	M6	3.4	PFL2100S	3φ-230V-100A-50/60Hz	VFS9-2150PM	230	150	210	60	90	8	—	M8	8.2	PFL4012S	3φ-460V-12.5A-50/60Hz	VFS9-4007PL~VFS9-4037PL	125	95	130	50	79	7	—	B	M4	2.3	PFL4025S	3φ-460V-25A-50/60Hz	VFS9-4055PL~VFS9-4110PL	155	110	155	50	94	7	—	M4	4.9	PFL4050S	3φ-460V-50A-50/60Hz	VFS9-4150PL	155	140	165	50	112	7	—	M6	6.6
Type	Rating				Inverter type	Dimensions (mm)										Drawing	Terminals	Approx. weight. (kg)																																																																																																																																												
		A	B	C		D	E	F	G																																																																																																																																																					
PFLS2002S	1φ-230V-2.0A-50/60Hz	VFS9S-2002PL	80	55	115	63	45	5	45	A	M3.5	0.85																																																																																																																																																		
PFL2001S	3φ-230V-1.7A-50/60Hz	VFS9-2002PM	105	65	115	90	55	5	40		M3.5	1.0																																																																																																																																																		
PFL2005S	3φ-230V-5.5A-50/60Hz	VFS9-2004PM, 2007PM VFS9S-2004PL, 2007PL	105	65	115	90	55	5	40		M3.5	1.2																																																																																																																																																		
PFL2011S	3φ-230V-11A-50/60Hz	VFS9-2015PM, 2022PM	130	70	140	115	60	5	50	B	M4	2.3																																																																																																																																																		
PFL2018S	3φ-230V-18A-50/60Hz	VFS9-2037PM, VFS9S-2015PL, VFS9S-2022PL	130	70	140	115	60	5	50		M4	2.5																																																																																																																																																		
PFL2025S	3φ-230V-25A-50/60Hz	VFS9-2055PL	125	100	130	50	83	7	—	B	M4	2.6																																																																																																																																																		
PFL2050S	3φ-230V-50A-50/60Hz	VFS9-2075PL, VFS9-2110PM	155	115	140	50	95	7	—		M6	3.4																																																																																																																																																		
PFL2100S	3φ-230V-100A-50/60Hz	VFS9-2150PM	230	150	210	60	90	8	—		M8	8.2																																																																																																																																																		
PFL4012S	3φ-460V-12.5A-50/60Hz	VFS9-4007PL~VFS9-4037PL	125	95	130	50	79	7	—	B	M4	2.3																																																																																																																																																		
PFL4025S	3φ-460V-25A-50/60Hz	VFS9-4055PL~VFS9-4110PL	155	110	155	50	94	7	—		M4	4.9																																																																																																																																																		
PFL4050S	3φ-460V-50A-50/60Hz	VFS9-4150PL	155	140	165	50	112	7	—		M6	6.6																																																																																																																																																		
DC reactor (DCL)	<p>Fig.A Fig.B Fig.C</p> <table border="1"> <thead> <tr> <th rowspan="2">Type</th> <th rowspan="2">Rated current (A)</th> <th rowspan="2">Inverter type</th> <th colspan="8">Dimensions (mm)</th> <th rowspan="2">Drawing</th> <th rowspan="2">Terminals</th> <th rowspan="2">Approx. weight. (kg)</th> </tr> <tr> <th>W</th> <th>H</th> <th>D</th> <th>X</th> <th>Y</th> <th>d1</th> <th>d2</th> </tr> </thead> <tbody> <tr> <td>DCL-2002</td> <td>—</td> <td>VFS9-2002PM</td> <td>59</td> <td>37</td> <td>35</td> <td>51</td> <td>—</td> <td>—</td> <td>—</td> <td rowspan="2">A</td> <td>V1.25-3.5</td> <td>0.2</td> </tr> <tr> <td>DCLS-2002</td> <td>2.5</td> <td>VFS9S-2002PL</td> <td>79</td> <td>50</td> <td>44</td> <td>66</td> <td>—</td> <td>—</td> <td>—</td> <td>V1.25-3.5</td> <td>0.6</td> </tr> <tr> <td>DCL-2007</td> <td>7</td> <td>VFS9-2004PM, 2007PM VFS9S-2004PL VFS9-4007PL, 4015PL (Note)</td> <td>92</td> <td>65</td> <td>70</td> <td>82</td> <td>—</td> <td>—</td> <td>—</td> <td rowspan="3">B</td> <td>V2-3.5</td> <td>1.2</td> </tr> <tr> <td>DCL-2022</td> <td>14</td> <td>VFS9-2015PM, 2022PM VFS9S-2007PL VFS9-4022PL, 4037PL (Note)</td> <td>86</td> <td>110</td> <td>80</td> <td>71</td> <td>64</td> <td>—</td> <td>—</td> <td>M4</td> <td>2.2</td> </tr> <tr> <td>DCL-2037</td> <td>22.5</td> <td>VFS9-2037PM VFS9S-2015PL, 2022PL</td> <td>86</td> <td>110</td> <td>85</td> <td>71</td> <td>70</td> <td>—</td> <td>55</td> <td>M4</td> <td>2.5</td> </tr> <tr> <td>DCL-2055</td> <td>38</td> <td>VFS9-2055PL</td> <td>75</td> <td>130</td> <td>140</td> <td>50</td> <td>85</td> <td>85</td> <td>55</td> <td rowspan="2">C</td> <td>M5</td> <td>1.9</td> </tr> <tr> <td>DCL-2110</td> <td>75</td> <td>VFS9-2075PL~VFS9-2110PM</td> <td>100</td> <td>150</td> <td>150</td> <td>65</td> <td>85</td> <td>95</td> <td>60</td> <td>M6</td> <td>2.4</td> </tr> <tr> <td>DCL-2220</td> <td>150</td> <td>VFS9-2150PM</td> <td>117</td> <td>170</td> <td>190</td> <td>90</td> <td>90</td> <td>130</td> <td>—</td> <td rowspan="3">C</td> <td>M8</td> <td>4.3</td> </tr> <tr> <td>DCL-4110</td> <td>38</td> <td>VFS9-4055PL~4110PL</td> <td>95</td> <td>150</td> <td>165</td> <td>70</td> <td>90</td> <td>105</td> <td>60</td> <td>M5</td> <td>3.0</td> </tr> <tr> <td>DCL-4220</td> <td>75</td> <td>VFS9-4150PL</td> <td>105</td> <td>160</td> <td>185</td> <td>80</td> <td>100</td> <td>130</td> <td>65</td> <td>M8</td> <td>3.7</td> </tr> </tbody> </table> <p>Note) VFS9-4007PL~4037PL are used DC reactor for 200V class.</p>	Type	Rated current (A)	Inverter type	Dimensions (mm)								Drawing	Terminals	Approx. weight. (kg)	W	H	D	X	Y	d1	d2	DCL-2002	—	VFS9-2002PM	59	37	35	51	—	—	—	A	V1.25-3.5	0.2	DCLS-2002	2.5	VFS9S-2002PL	79	50	44	66	—	—	—	V1.25-3.5	0.6	DCL-2007	7	VFS9-2004PM, 2007PM VFS9S-2004PL VFS9-4007PL, 4015PL (Note)	92	65	70	82	—	—	—	B	V2-3.5	1.2	DCL-2022	14	VFS9-2015PM, 2022PM VFS9S-2007PL VFS9-4022PL, 4037PL (Note)	86	110	80	71	64	—	—	M4	2.2	DCL-2037	22.5	VFS9-2037PM VFS9S-2015PL, 2022PL	86	110	85	71	70	—	55	M4	2.5	DCL-2055	38	VFS9-2055PL	75	130	140	50	85	85	55	C	M5	1.9	DCL-2110	75	VFS9-2075PL~VFS9-2110PM	100	150	150	65	85	95	60	M6	2.4	DCL-2220	150	VFS9-2150PM	117	170	190	90	90	130	—	C	M8	4.3	DCL-4110	38	VFS9-4055PL~4110PL	95	150	165	70	90	105	60	M5	3.0	DCL-4220	75	VFS9-4150PL	105	160	185	80	100	130	65	M8	3.7												
Type	Rated current (A)				Inverter type	Dimensions (mm)										Drawing	Terminals	Approx. weight. (kg)																																																																																																																																												
		W	H	D		X	Y	d1	d2																																																																																																																																																					
DCL-2002	—	VFS9-2002PM	59	37	35	51	—	—	—	A	V1.25-3.5	0.2																																																																																																																																																		
DCLS-2002	2.5	VFS9S-2002PL	79	50	44	66	—	—	—		V1.25-3.5	0.6																																																																																																																																																		
DCL-2007	7	VFS9-2004PM, 2007PM VFS9S-2004PL VFS9-4007PL, 4015PL (Note)	92	65	70	82	—	—	—	B	V2-3.5	1.2																																																																																																																																																		
DCL-2022	14	VFS9-2015PM, 2022PM VFS9S-2007PL VFS9-4022PL, 4037PL (Note)	86	110	80	71	64	—	—		M4	2.2																																																																																																																																																		
DCL-2037	22.5	VFS9-2037PM VFS9S-2015PL, 2022PL	86	110	85	71	70	—	55		M4	2.5																																																																																																																																																		
DCL-2055	38	VFS9-2055PL	75	130	140	50	85	85	55	C	M5	1.9																																																																																																																																																		
DCL-2110	75	VFS9-2075PL~VFS9-2110PM	100	150	150	65	85	95	60		M6	2.4																																																																																																																																																		
DCL-2220	150	VFS9-2150PM	117	170	190	90	90	130	—	C	M8	4.3																																																																																																																																																		
DCL-4110	38	VFS9-4055PL~4110PL	95	150	165	70	90	105	60		M5	3.0																																																																																																																																																		
DCL-4220	75	VFS9-4150PL	105	160	185	80	100	130	65		M8	3.7																																																																																																																																																		

**Device** High-attenuation radio noise reduction filter

**External dimensions and connections**

Note) ① Noise filter should be connected to the primary-side of inverter.  
② Out put cable should be kept away from input cable.

Type	Rated current (A)	Inverter type	Dimensions (mm)													Approx. weight. (kg)		
			A	B	C	E	F	G	H	J	K	M	N	P				
NF3005A-MJ	5	VFS9-2002PM-VFS9-2007PM																1.0
NF3015A-MJ	15	VFS9-2015PM, VFS9-2022PM	174.5	160	145	110	80	32	70	20	45	φ5.5	M4				1.6	
NF3020A-MJ	20	VFS9-2037PM															4.6	
NF3050A-MJ	50	VFS9-2110PM	267.5	250	235	170	140	44	90		60						4.6	
NF3080A-MJ	80	VFS9-2150PM	294.5	280	260	170	150	37	100	30	65	φ6.5	M6				7.0	

Note) End of type of Inverter : -PL has a built-in the high-attenuation radio noise reduction filter

**Device** Zero-phase ferrite core type radio noise reduction filter

Type : RC9129      Type : RC5078      Unit : mm

Zero-phase reactor

Input or output cable should be coiled over 4-times.

**Device** Foot-mounted noise filter

Type	Rated current (A)	Inverter type	Dimensions (mm)							Leakage current(mA) note)				
			W	H	D	W1	H1	D2	E		F	G		
EMFS2010AZ	10	VFS9S-2002PL~2007PL												76
EMF2011BZ	11	VFS9-2002PM~2015PM	105	185	50	85	170							84
EMFS2016CZ	16	VFS9S-2015PL	130	205		110	190							70
EMF4006CZ	6	VFS9-4007PL, 4015PL							10	8.5	4.5			200
EMFS2025DZ	25	VFS9S-2022PL												78
EMF4022DZ	22	VFS9-2022PM, 2037PM	140	250		120	230	2						170
		VFS9-4022PL, 4037PL				60								400
EMF4045EZ	45	VFS9-2055PL, 2075PL, 4055PL, 4075PL	200	351		160	330							180
EMF4045FZ	45	VFS9-4110PL, 4150PL												400
EMF2080GZ*	80	VFS9-2110PM, 2150PM	245	372		250	360		11	9.5	5.5			400
														110

\*Install grounding cable between the filter and EMC plate to conform to "EN55011 Group 1 class A".(EMF2080GZ)  
wire size : 6mm<sup>2</sup> or more (AWG9 or more)  
wire length : 0.29m or less  
note) In case of the delta connection.(Primary side of the inverter)

**Device** Braking resistor

**External dimensions and connections**

Type	Rating	Inverter type	Dimensions (mm)						Drawing	Approx. weight. (kg)
			A	B	C	D	E	G		
PBR-2007	120W-200Ω	VFS9-2002PM-VFS9-2007PM VFS9S-2002PL-VFS9S-2007PL VFS9-4007PL-VFS9-4022PL Note)	42	182	20	4.2	172	—	A & C	0.28
PBR-2022	120W-75Ω	VFS9-2015PM-VFS9-2022PM VFS9S-2015PL, 2022PL								
PBR-2037	120W-40Ω	VFS9-2037PM								
PBR3-2055	120W-40Ωx2P (240W-20Ω)	VFS9-2055PL		320	115			50		4
PBR3-2075	220W-30Ωx2P (440W-15Ω)	VFS9-2075PL	120						B & D	4.5
PBR3-2110	220W-30Ωx3P (660W-10Ω)	VFS9-2110PM		350	190	110	230	150		5
PBR3-2150	220W-30Ωx4P (880W-7.5Ω)	VFS9-2150PM								5.5
PBR-4037	120W-160Ω	VFS9-4037PL	42	182	20	4.2	172	—	A & C	0.28
PBR3-4055	120W-160Ωx2P (240W-80Ω)	VFS9-4055PL		320	115			50		4
PBR3-4075	220W-120Ωx2P (440W-60Ω)	VFS9-4075PL	120						B & D	4.5
PBR3-4110	220W-120Ωx3P (660W-40Ω)	VFS9-4110PL		350	190	110	230	150		5
PBR3-4150	120W-120Ωx4P (880W-30Ω)	VFS9-4150PL								5.5

Note) VFS9-4007PL-4022PL are used braking resistor for 200V class.

**Parameter writer Extension panel Communication Converter unit (RS485/RS232C)**

**Parameter writer**      **Extension panel**      **Communication Converter Unit RS485/RS232C**

Note) Dimensions of extension panel are same as following drawing, but the surface of panel are different.

Note) Following is RS485 unit. Dimensions of RS232C unit are same as following, but RS232C doesn't have a connector.

Parameter writer type: PWU001Z  
Parameter writer cable type: CAB0011(1m), CAB0013(3m), CAB0015(5m)

Extension panel type: PKP001Z  
Extension panel cable type: CAB0011(1m), CAB0013(3m), CAB0015(5m)

RS485 communication converter type: RS4001Z  
RS485 cable type: CAB0011(1m), CAB0013(3m), CAB0015(5m)

RS232C communication converter type: RS2001Z  
Computer cable type: CAB0025  
RS232C cable type: CAB0011(1m), CAB0013(3m), CAB0015(5m)

